

DV1000·3000·4000 Series

5 Port pilot type solenoid valve

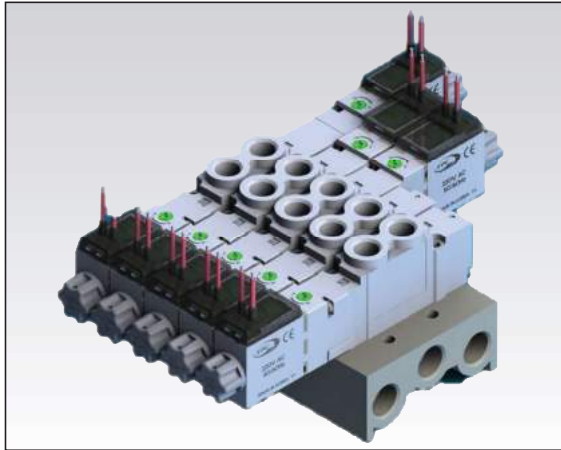

- **Quick response time & large flow capacity**
 - Reponse time is less than 12ms (DV 1000)
 - Increased CV factor (2.5 times larger than conventional valve)
 - Low power consumption: 0.85W (24V DC, 41mA)
- **High reliability**
 - Long lifespan
 - Wear Ring → prevents spool abrasion
 - U Packing → minimizes frictional resistance
 - Piston return type at retraction
- **Variety of features**
 - Common exhaust type as standard option
 - Option for built-in fitting is available (body-ported type)
 - Implemented an external pilot type (DV1000, 3000, 4000)

How to order

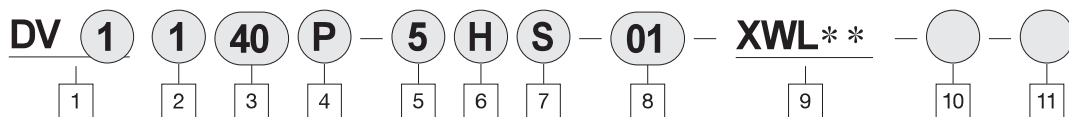

- 1 DV Valve Series**
 1 : DV1000 Series
 3 : DV3000 Series
 4 : DV4000 Series

- 2 Configuration**
 1 : Single Solenoid
 2 : Double Solenoid
 3 : Closed Center
 4 : Exhaust Center
 5 : Pressure Center

- 3 Manifold specifications**
 40 : Base ported
 ※ Built-in fitting type is only available with body ported type

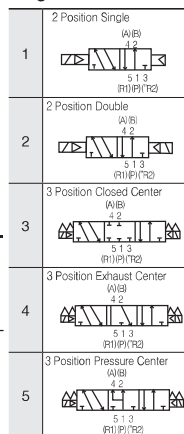

- 4 Pilot configuration**
 Blank: Internal pilot
 P: External pilot (only applicable to base-mounted type)

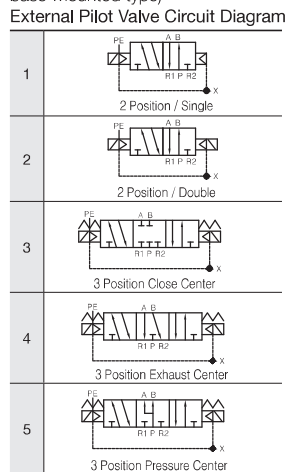

- 5 Voltage**
 5 : DC24V 1 : AC110V
 6 : DC12V 2 : AC220V

- 6 Electrical entry**
 V: Vertical connector (AV voltage not available)
 H: Horizontal connector
 G: Grommet type (Lamp as standard option)
 D: Din terminal type (Without lamp)
 DZ: Din terminal type (With lamp)
 ※ G, D, and DZ types are only available with DV3000 and DV4000 series

- 7 PCB Type**
 Blank: Basic type (Lamp, surge protection circuit type)
 D: Non-polar type (Lamp, surge protection circuit type)
 N: No lead wire
 S: Power saving PCB Type (0.45W/DC24V)
 ※ Option D only applies to DC voltage with V or H option
 ※ Option S only applies to DC voltage with V, H, or G option

- 8 Port size**
 ※ Sub Plate attachment (only for base piping)
 Blank: Without sub plate
 M5 : M5×0.8(DV1000 Series)
 01 : Rc(PT)1/8(DV3000 Series)
 02 : Rc(PT)1/4(DV4000 Series)

- 9 Length of lead wire**
 Blank : 400mm(Standard)
 XWL 01 : 100mm
 XWL 02 : 200mm
 ...
 20 : 2000mm

- 10 Series**
 Blank: Standard type XC16: Copper-free type
 ※ Fitting built-in specification (Direct piping type)

Symbol	Content	Application series
Blank	Blank: Built-in fitting	All series
T4	T4 Ø4 One touch Fitting	DV1000 Series
T6	T6 Ø6 One touch Fitting	
T4	T4 Ø4 One touch Fitting	DV3000 Series
T6	T6 Ø6 One touch Fitting	
T8	T8 Ø8 One touch Fitting	DV4000 Series
T8	T8 Ø8 One touch Fitting	
T10	T10 Ø10 One touch Fitting	

- 11 OPTION**
 Blank: No bracket
 FB: Foot bracket
 SB: Side bracket
 Note 1) FOOT type is only for single type,
 Note 2) The bracket is not assembled and shipped.
 Note 3) Bracket option is available for DV 1000, DV 3000 only.

DWLN Series

How to order coil ass'y (G,D,DZ)

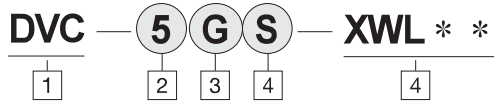

- 1 DV Valve Coil Ass'y**
- 2 Voltage**
1 : AC 110V
2 : AC 220V
5 : DC 24V
6 : DC 12V
- 3 Electrical entry**
G : Grommet type (With lamp)
D : Din terminal type (Without lamp)
DZ : Din terminal type (With lamp)
- 4 PCB Type**
Blank : Basic type (Lamp, surge protection circuit type)
N : No lead wire
S : Power saving PCB type (0,45W/DC24V)
※ Option S only applies to DC voltage with G option
- 5 Length of lead wire**
Blank : 400mm (standard)
XWL 01 : 100mm
02 : 200mm
:
20 : 2000mm
※ Please contact us for lengths not listed above.

How to order port plug ass'y



- 1 DV Series**
1 : DV1000 Series
3 : DV3000 Series
4 : DV4000 Series
- 2 Built-in fitting options (Direct piping type)**

Symbol	Content	Application series
T4	Ø4 One Touch Fitting	DV1000
T6	Ø6 One Touch Fitting	
T4	Ø4 One Touch Fitting	DV3000
T6	Ø6 One Touch Fitting	
T8	Ø8 One Touch Fitting	DV4000
T8	Ø8 One Touch Fitting	
T10	Ø10 One Touch Fitting	
Blank	No fitting	All series

Part number for manifold gasket

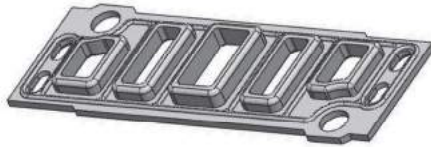

DV1000	Body ported type	DV1120-52-2078-PL
	Base ported type	DV1140-52-2083-PL
	Bolt	M2X0.4X21 L-PL
DV3000	Body ported type	DV3120-52-2088-PL
	Base ported type	DV3140-52-2088-PL
	Bolt	M3X0.5X27L-PL
DV4000	Body ported type	DV4120-52-2102-PL
	Base ported type	DV4140-52-2107-PL
	Bolt	M4X0.7X32L-PL

Part number for blank plate

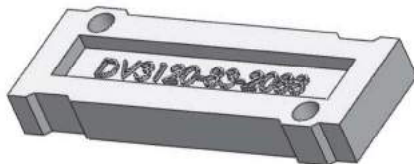

DV1000	Body ported type	DVB1120
	Base ported type	DVB1140
DV3000	Body ported type	DVB3120
	Base ported type	DVB3140
DV4000	Body ported type	DVB4120
	Base ported type	DVB4140

※ Part number of mounting bracket
DV1000 : DV1000-B2 DV3000 : DV3000-B

Part number for side bracket

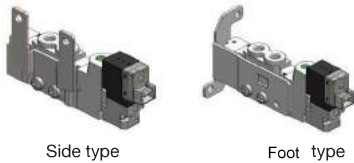

Side type

Foot type

DV1000	Foot type	DV1000-FB
	Side type	DV1000-SB
DV3000	Foot type	DV3000-FB
	Side type	DV3000-SB

Part number for lead wire



DV1000	121-803-PL
DV3000	
DV4000	

Series DV1000

Manifold



Body ported(Plug Type)



Base Mounted(Grommet Type)



Body ported(DIN Type)

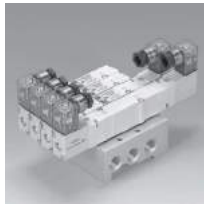

Base Mounted(DIN Type)

Specifications

Series	DV1000		DV3000		DV4000		
Action	5 Port Pilot Type Solenoid Valve(Rubber Seal)						
Fluid	Air (Vacuum is Available)						
Operating Pressure	2Position Single	0.25~0.7(2.5~7.1)		0.15~0.7(1.5~7.1)			
Range(MPa, kgf/cm ²)	2Position Double	0.25~0.7(2.5~7.1)		0.1~0.7(1~7.1)			
	3 Position	0.25~0.7(2.5~7.1)		0.2~0.7(2~7.1)			
Main (P, A, B Port) Use Pressurer (MPa)	-100KPa ~ 0.7						
Ambient and Fluid Temperature C(°F)	MAX. 50°C (122°F)						
Manual Override	Push&Lock Type						
Pilot Exhaust Type	Individual exhaust Common exhaust for main valve and pilot Valve						
	Mainfold PE Port Command Exhaust Type(Separed Piping)			-			
Lubrication	Not Required						
Mounting Position	Free						
Impact/Vibration	H.V	150/30(8.3~2000Hz)					
Resistance(m/s ²)	G, D, DZ	300/50					
Max. Operating Frequency	2Position	10		5		5	
	3 Position	3		3		3	
Protection Structure	Dust Proof						
Lead Electrical Entry	Connector Mounting Type (H:Horizontal, V:Vertical), Grommet, Din Terminal Type						
Voltage	DC12, DC24V, AC110V, AC220V						
Voltage Allowance	-10(%)~+10(%)of Rated Voltage						
Polarity	Non-polar (standard) (*DC24V:Polarity type)						
Response Time(ms)	at 5kgf/cm ² (71.1psi)	H.V	~12ms		~18ms		30ms
		G, D, DZ	-		~26ms		38ms
Power Consumption(W)	H.V	1.0(*DC24V:0.6) (Indicator Light and Surge suppressor)					
Effective Orifice	Single	3.6mm ² (Cv0.2)		9.0mm ² (Cv0.5)		16.2mm ² (Cv0.9)	
		-		-		-	

* The other options same as standard type(Body ported type DV1000, 3000)

Series DV1000 · 3000 · 4000 Body Ported Type Effective Orifice and Reponse Time

Type	Valve Model	Port Size Rc(PT)/NPT	Configuration	Operating Pressure Range Mpa(psi)	Effective Orifice (mm ²) (Cv)	Response Time(ms)		Weight · g(oz)	
						H, V	G, D, DZ		
DV1120-O-M5	DV 1120	M5/ 10-32 UNF	2	Single	0.15~0.70 (20~100)	3.6 (0.20)	~12	-	52(1.83)
DV1220-O-M5	DV 1220			Double	0.10~0.70 (14~100)	3.6 (0.20)	~10	-	64(2.26)
DV1320-O-M5	DV 1320		3	Closed Center	0.20~0.70 (27~100)	3.3 (0.18)	~16	-	68(2.4)
DV1420-O-M5	DV 1420			Exhaust Center	0.20~0.70 (27~100)	3.3 (0.18)	~16	-	68(2.4)
DV1520-O-M5	DV 1520			Pressure Center	0.20~0.70 (27~100)	3.6 (0.20)	~16	-	68(2.4)
DV3120-O-M5	DV 3120			Rc(PT)/NPT 1/8"	2	Single	0.15~0.70 (20~100)	9.0 (0.50)	~18
DV3220-O-M5	DV 3220	Double	0.10~0.70 (14~100)			9.0 (0.50)	~18	~22	134(4.72)
DV3320-O-M5	DV 3320	3	Closed Center		0.20~0.70 (27~100)	7.2 (0.40)	~32	~38	142(5.01)
DV3420-O-M5	DV 3420		Exhaust Center		0.20~0.70 (27~100)	7.2 (0.40)	~32	~38	142(5.01)
DV3520-O-M5	DV 3520		Pressure Center		0.20~0.70 (27~100)	9.5 (0.53)	~32	~38	142(5.01)
DV4120-O-M5	DV 4120		Rc(PT)/NPT1 1/4"		2	Single	0.15~0.70 (20~100)	16.2 (0.90)	~30
DV4220-O-M5	DV 4220	Double		0.10~0.70 (14~100)		16.2 (0.90)	~30	~30	136(4.8)
DV4320-O-M5	DV 4320	3		Closed Center	0.20~0.70 (27~100)	10.8 (0.60)	~50	~56	144(5.08)
DV4420-O-M5	DV 4420			Exhaust Center	0.20~0.70 (27~100)	10.8 (0.60)	~50	~56	144(5.08)
DV4520-O-M5	DV 4520			Pressure Center	0.20~0.70 (27~100)	17.1 (0.96)	~50	~56	144(5.08)

Series DV1000 · 3000 · 4000 Base Mounted Type Effective Orifice and Reponse Time

Type	Valve Model	Port Size		Configuration	Operating Pressure Range Mpa(psi)	Effective Orifice (mm ²) (Cv)	Response Time(ms)		Weight · g(oz)
		P, R1, R2	A, B				H, V	G, D, DZ	
DV1140-O-M5	DV 1140	Rc(PT)/NPT 1/8"	2	Single	0.15~0.70 (20~100)	4.0 (0.22)	~12	-	46(1.62)
DV1240-O-M5	DV 1240			Double	0.10~0.70 (14~100)	4.0 (0.22)	~10	-	58(2.05)
DV1340-O-M5	DV 1340		3	Closed Center	0.20~0.70 (27~100)	3.6 (0.20)	~16	-	62(2.19)
DV1440-O-M5	DV 1440			Exhaust Center	0.20~0.70 (27~100)	3.6 (0.20)	~16	-	62(2.19)
DV1540-O-M5	DV 1540			Pressure Center	0.20~0.70 (27~100)	3.8 (0.21)	~16	-	62(2.19)
DV3140-O-M5	DV 3140			Rc(PT)/NPT 1/4"	2	Single	0.15~0.70 (20~100)	9.5 (0.53)	~18
DV3240-O-M5	DV 3240	Double	0.10~0.70 (14~100)			9.5 (0.53)	~18	~22	106(3.74)
DV3340-O-M5	DV 3340	3	Closed Center		0.20~0.70 (27~100)	7.2 (0.40)	~32	~38	114(4.02)
DV3440-O-M5	DV 3440		Exhaust Center		0.20~0.70 (27~100)	7.2 (0.40)	~32	~38	114(4.02)
DV3540-O-M5	DV 3540		Pressure Center		0.20~0.70 (27~100)	10.0 (0.55)	~32	~38	114(4.02)
DV4140-O-M5	DV 4140		Rc(PT)/NPT 3/8"		2	Single	0.15~0.70 (20~100)	16.2 (0.90)	~30
DV4240-O-M5	DV 4240	Double		0.10~0.70 (14~100)		16.2 (0.90)	~30	~30	96(3.4)
DV4340-O-M5	DV 4340	3		Closed Center	0.20~0.70 (27~100)	10.8 (0.60)	~50	~56	104(3.67)
DV4440-O-M5	DV 4440			Exhaust Center	0.20~0.70 (27~100)	10.8 (0.60)	~50	~56	104(3.67)
DV4540-O-M5	DV 4540			Pressure Center	0.20~0.70 (27~100)	17.1 (0.96)	~50	~56	104(3.67)

DW

DR100

DR200

RS1000, 2000

RS4000

SI UNIT

DV1000
DV3000
DV4000

DS300

DS3000

DS5000

DS2000

DS6000

DX1,DX2

DX1(2)R

DH

DP300
DP3000
DP5000

DM

DT220

Series DV1000

Construction / Body Ported type

2 Position Single

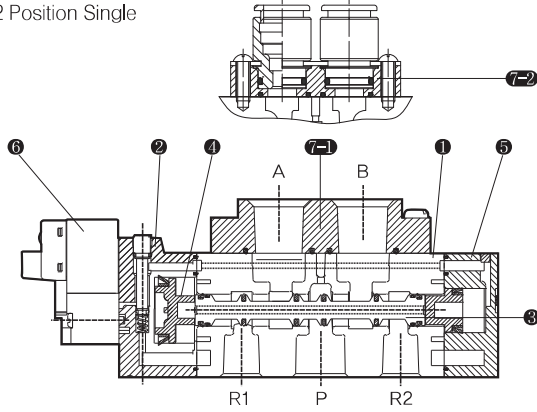

Main parts

No.	Description	Material	Note
1	Body	Aluminum die cast	(DV4000)Aluminum Die Cast
2	Adapter plate	Resin	
3	Spool	Aluminum	
4	Piston	Resin	
5	End cover	Resin	
6	Solenoid ass'y	-	
7-1	Port Plug Ass'y	-	Standard
7-2			Fitting Type

Construction / Base mounted type

2 Position Single

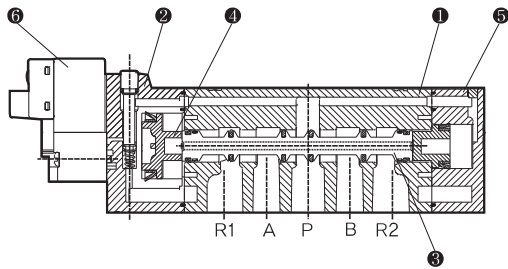

Main parts

No.	Description	Material	Note
1	Body	Aluminum die cast	(DV4000)Aluminum Die Cast
2	Adapter plate	Resin	
3	Spool	Aluminum	
4	Piston	Resin	
5	End cover	Resin	
6	Solenoid ass'y	-	

Construction / Grommet type

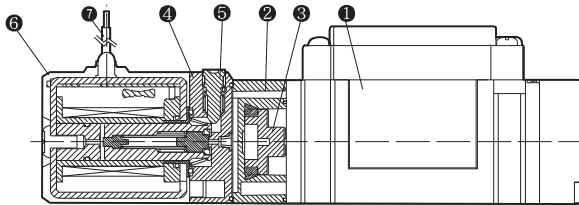

Main parts

No.	Description	Material	Note
1	Body	-	DV3000/DV4000 SERIES
2	Adapter plate	Resin	
3	Piston	Resin	
4	Pilot body	Resin	
5	Manual	Resin	
6	Solenoid coil	-	
7	Lead wire	-	

Construction / Din terminal type

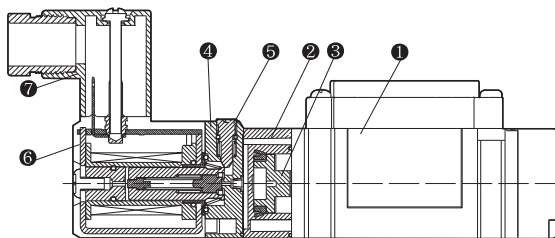

Main parts

No.	Description	Material	Note
1	Body	-	DV3000/DV4000 SERIES
2	Adapter plate	Resin	
3	Piston	Resin	
4	Pilot body	Resin	
5	Manual	Resin	
6	Solenoid coil	-	
7	Din connector ass'y	-	mpm

Series DV1000

Series DV1000 / 2 Position / H: Horizontal Connector Type

DV1000 Fitting Included Dimension Drawing (Body Ported Type)

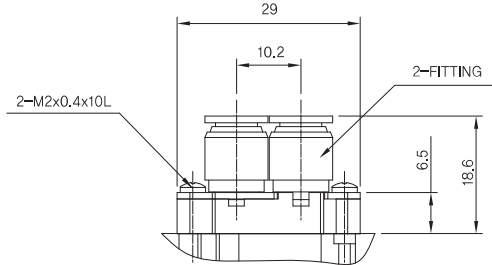

※The other options same as DV1000 standard type (Body ported type)

DV1120 Single / Body Ported Type

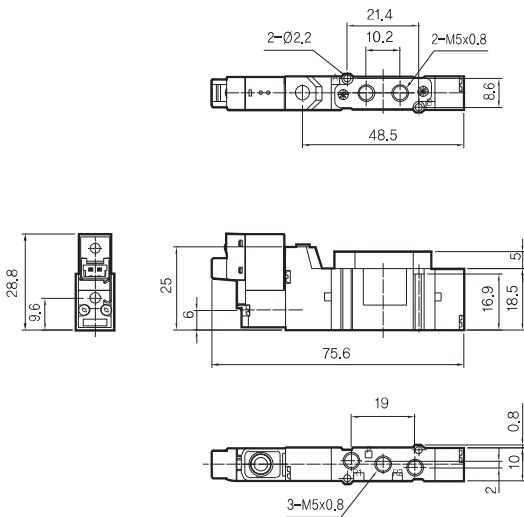

DV1140 Single / Base Mounted Type

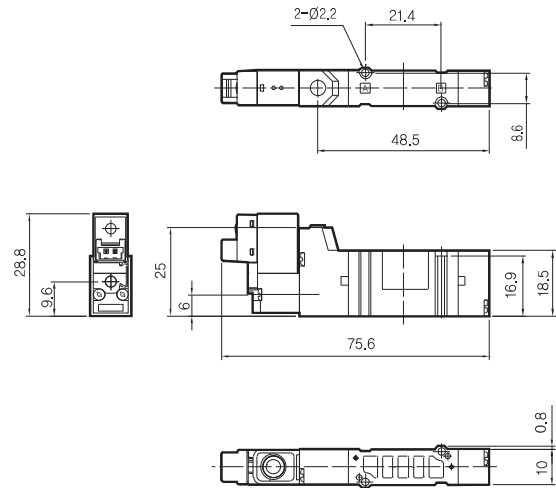

DV1220 Double / Body Ported Type

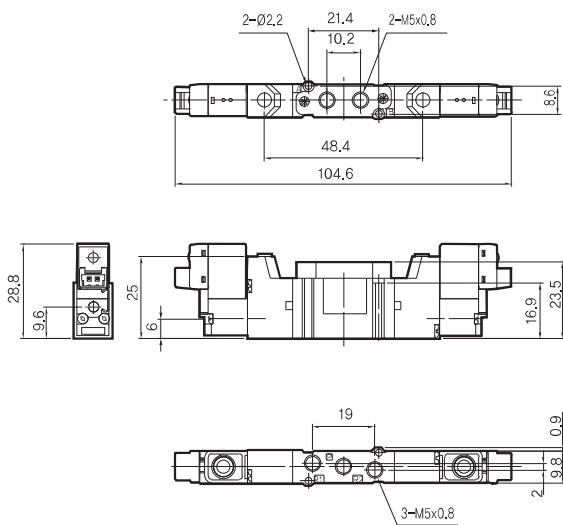

DV1240 Double / Base Mounted Type

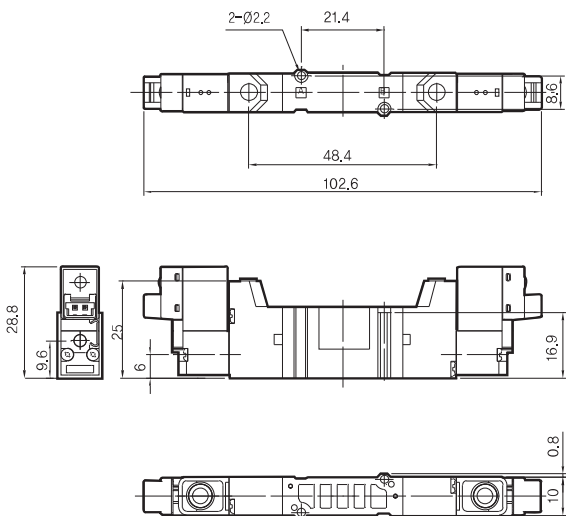

DW
DR100
DR200
RS1000, 2000
RS4000
SI UNIT
DV1000 DV3000 DV4000
DS300
DS3000
DS5000
DS2000
DS6000
DX1,DX2
DX1(2)R
DH
DP300 DP3000 DP5000
DM
DT220

Series DV1000

Series DV1000 / 2 Position / V: Vertical Connector Type

(Unit:mm)

DV1120 Single / Body Ported Type

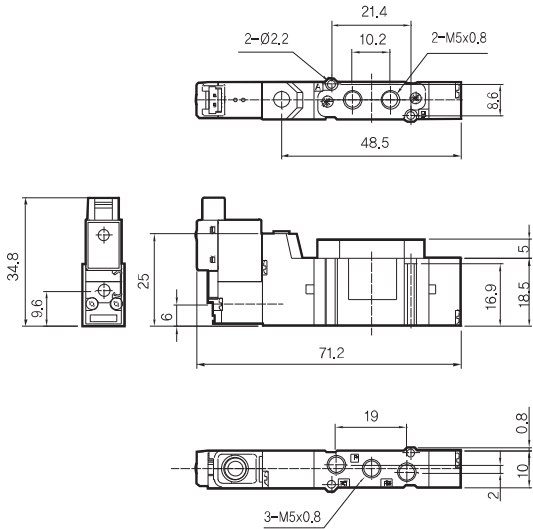

DV1140 Single / Base Mounted Type

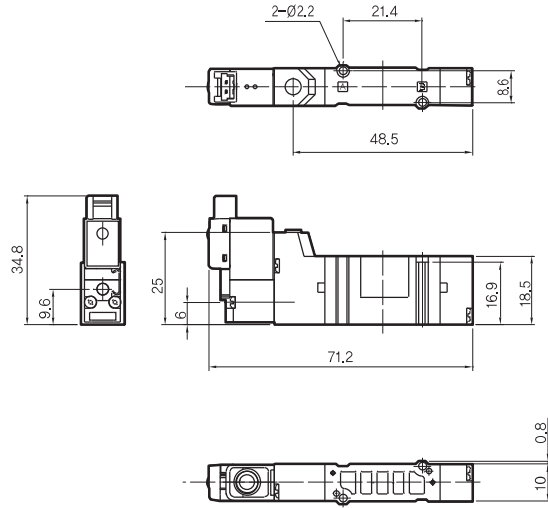

DV1220 Double / Body Ported Type

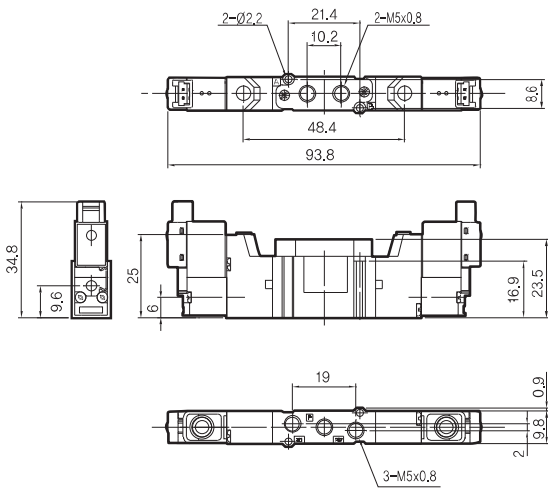

DV1240 Double / Base Mounted Type

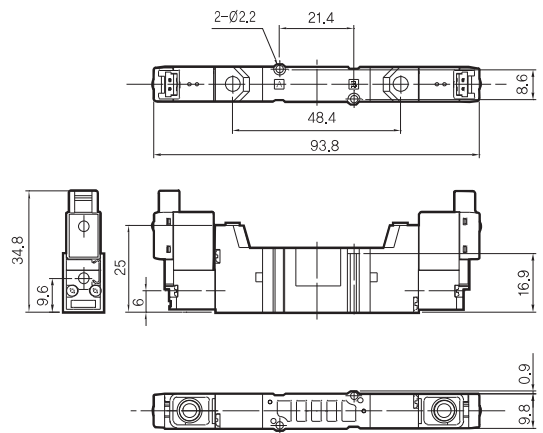

Series DV1000

Series DV1000 / 3 Position / H: Horizontal Connector Type

(Unit: mm)

DV1320/1420/1520 3 Position / Body Ported Type

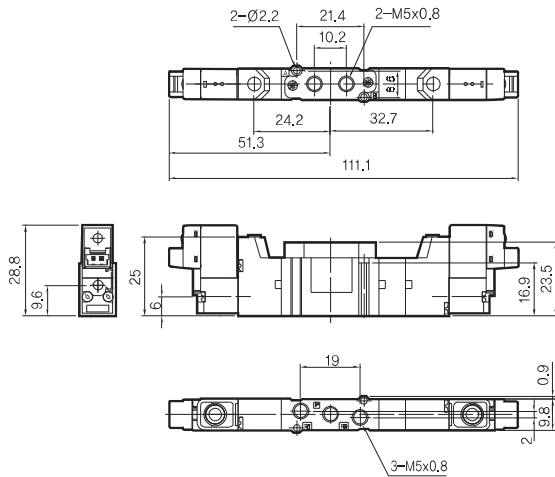

DV1340/1440/1540 3 Position / Base Mounted Type

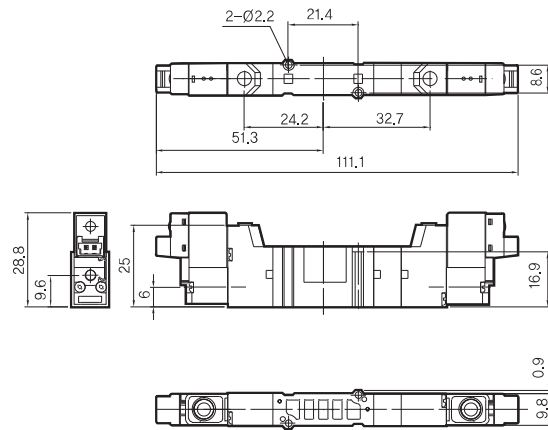

Series DV1000 / 3 Position / V: Vertical Connector Type

(Unit: mm)

DV1320/1420/1520 3 Position / Body Ported Type

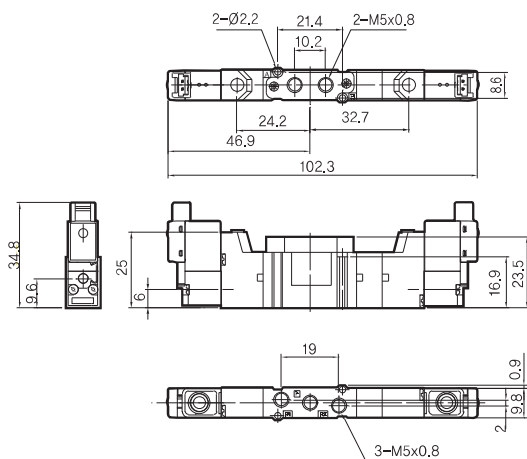

DV1340/1440/1540 3 Position / Base Mounted Type

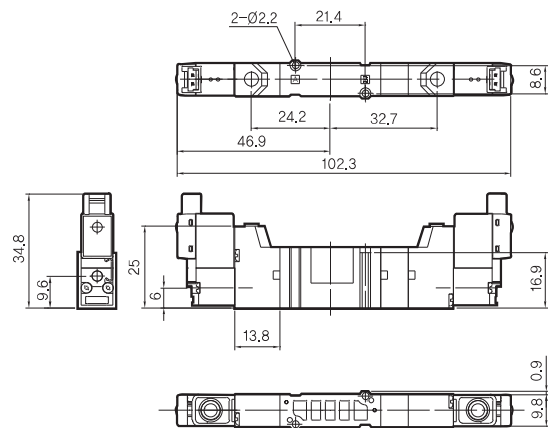

- DW
- DR100
- DR200
- RS1000, 2000
- RS4000
- SI UNIT
- DV1000**
- DV3000
- DV4000
- DS300
- DS3000
- DS5000
- DS2000
- DS6000
- DX1,DX2
- DX1(2)R
- DH
- DP300
- DP3000
- DP5000
- DM
- DT220

Series DV1000

Manifold Dimensions / Series DV1000 (Body Ported) / H: Horizontal Connector Type

(Unit: mm)

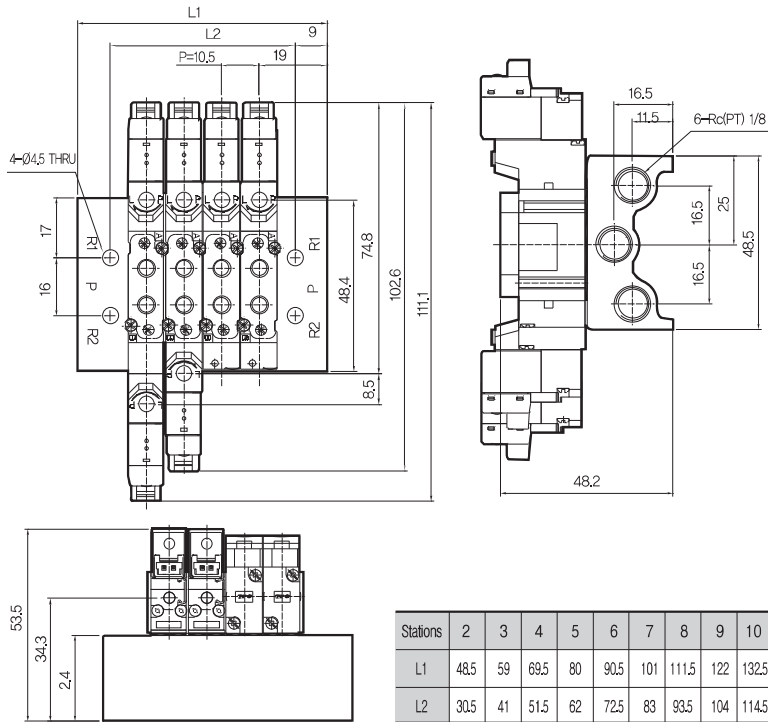

How to order

DVM1 — **20** — **05**

1 2 3

1 DV1000 Manifold
2 Body Ported Type
3 Stations (2~20)

	(mm)																			
Stations	2	3	4	5	6	7	8	9	10	11	12	13	14	15	16	17	18	19	20	
L1	48.5	59	69.5	80	90.5	101	111.5	122	132.5	143	153.5	164	174.5	185	195.5	206	216.5	227	237.5	
L2	30.5	41	51.5	62	72.5	83	93.5	104	114.5	125	135.5	146	156.5	167	177.5	188	198.5	209	219.5	

Manifold Dimensions / Series DV1000 (Base Mounted) / H: Horizontal Connector Type

(Unit: mm)

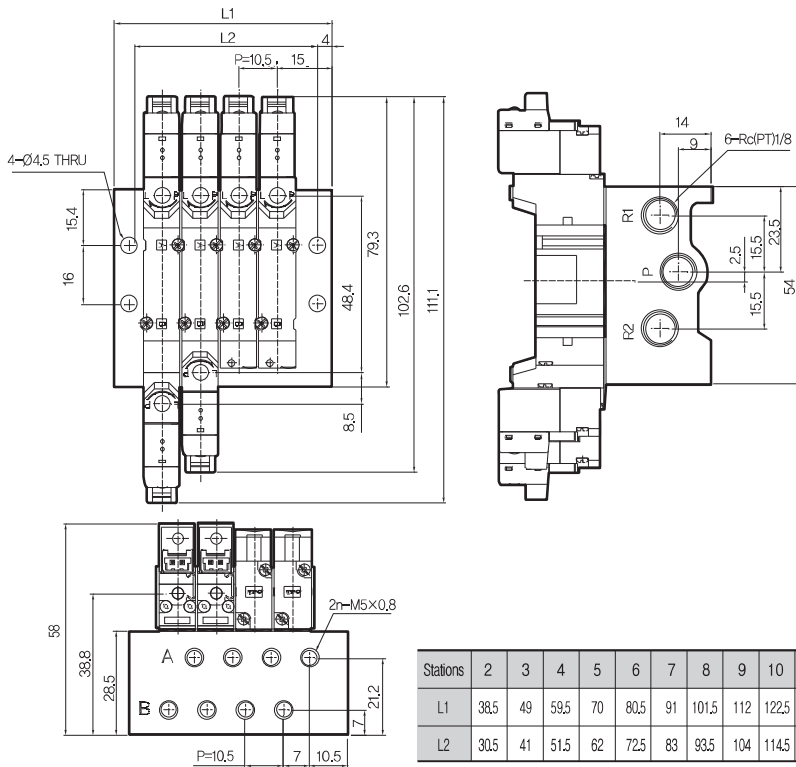

How To Order

DVM1 — **40** — **05**

1 2 3

1 DV1000 Manifold
2 Base Mounted type
3 Stations (2~20)

	(mm)																			
Stations	2	3	4	5	6	7	8	9	10	11	12	13	14	15	16	17	18	19	20	
L1	38.5	49	59.5	70	80.5	91	101.5	112	122.5	133	143.5	154	164.5	175	185.5	196	206.5	217	227.5	
L2	30.5	41	51.5	62	72.5	83	93.5	104	114.5	125	135.5	146	156.5	167	177.5	188	198.5	209	219.5	

Series DV1000

Dimensions / Series DV1000 (Body Ported) / V: Vertical Connector Type

(Unit: mm)

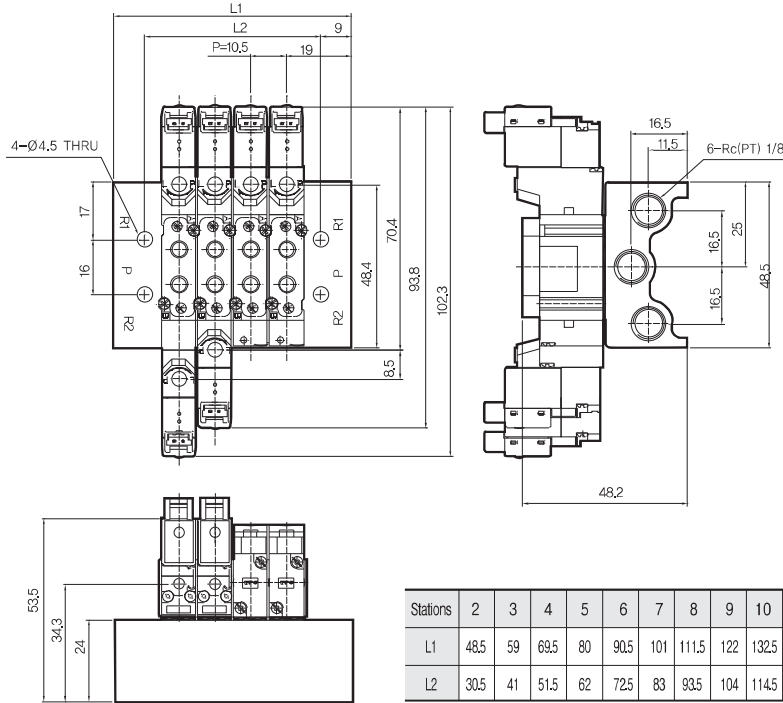

How To Order

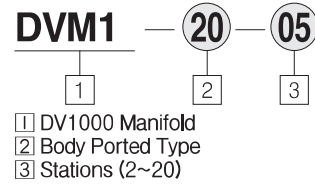

Stations	2	3	4	5	6	7	8	9	10	11	12	13	14	15	16	17	18	19	20
L1	48.5	59	69.5	80	90.5	101	111.5	122	132.5	143	153.5	164	174.5	185	195.5	206	216.5	227	237.5
L2	30.5	41	51.5	62	72.5	83	93.5	104	114.5	125	135.5	146	156.5	167	177.5	188	198.5	209	219.5

Dimensions / Series DV1000 (Base Mounted) / V: Vertical Connector Type

(Unit: mm)

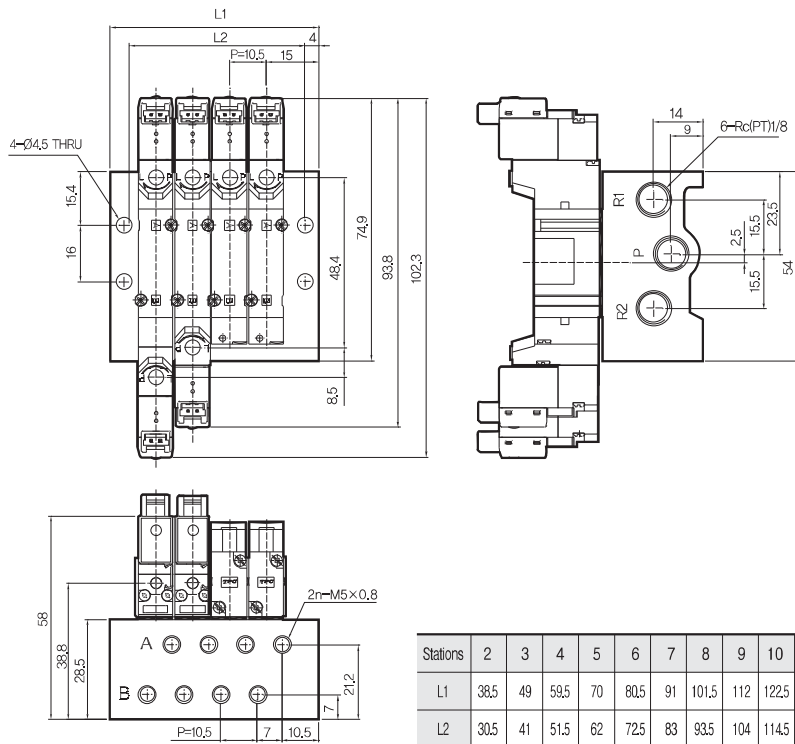

How To Order

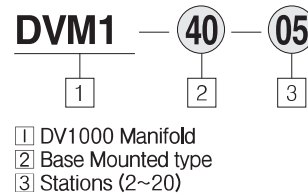

Stations	2	3	4	5	6	7	8	9	10	11	12	13	14	15	16	17	18	19	20
L1	38.5	49	59.5	70	80.5	91	101.5	112	122.5	133	143.5	154	164.5	175	185.5	196	206.5	217	227.5
L2	30.5	41	51.5	62	72.5	83	93.5	104	114.5	125	135.5	146	156.5	167	177.5	188	198.5	209	219.5

- DW
- DR100
- DR200
- RS1000, 2000
- RS4000
- SI UNIT
- DV1000
- DV3000
- DV4000
- DS300
- DS3000
- DS5000
- DS2000
- DS6000
- DX1,DX2
- DX1(2)R
- DH
- DP300
- DP3000
- DP5000
- DM
- DT220

Series DV3000

Series DV3000 / 2 Position / H: Horizontal Connector Type

(Unit:mm)

DV3000 Fitting Included Dimension Drawing(Body Ported Type)

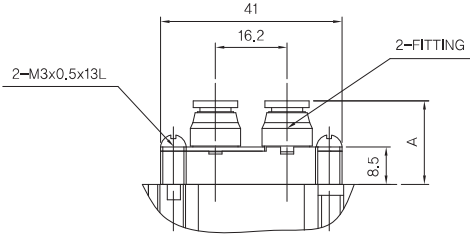

※The other options same as DV3000 standard type(Body ported type)

Series	Applicable Fitting Size	A	Note
DV3000	Ø4	18,9	
	Ø6	24	
	Ø8	24,8	

DV3120 Single / Body Ported Type

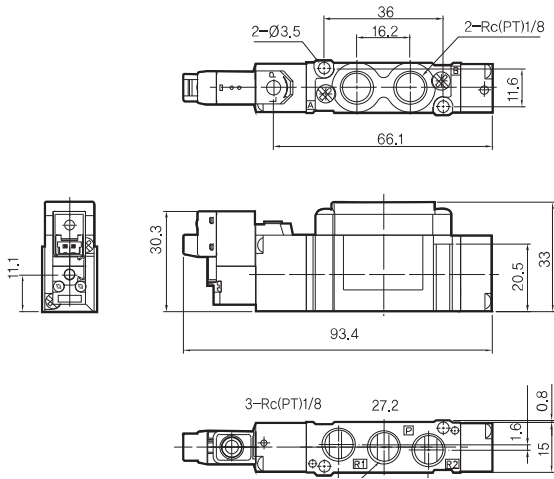

DV3140 Single / Base Mounted Type

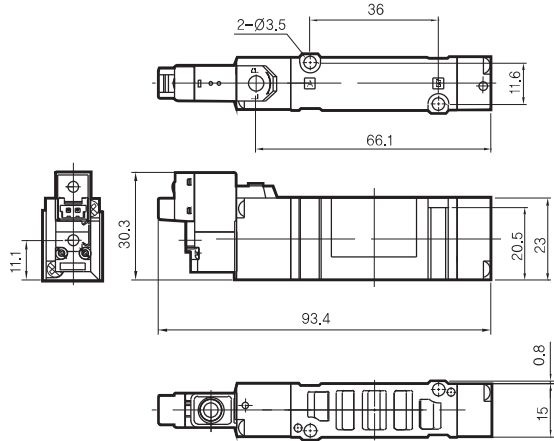

Series DV3000 / 2 Position / V: Vertical Connector Type

DV3120 Single / Body Ported Type

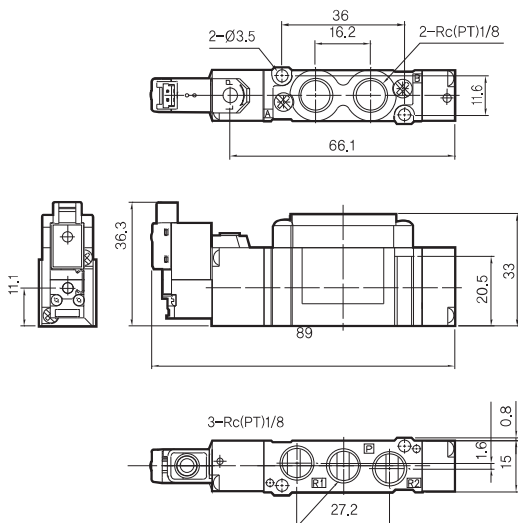

DV3140 Single / Base Mounted Type

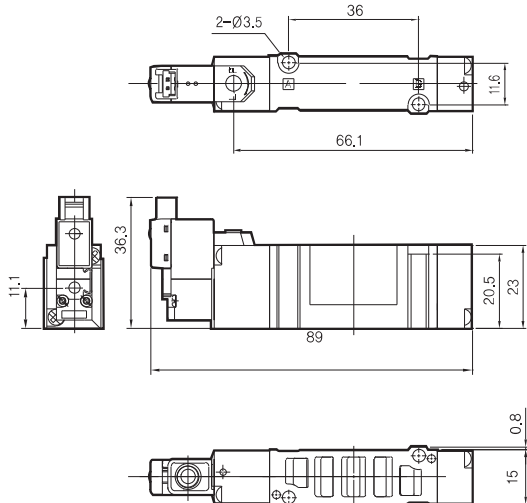

Series DV3000

Series DV3000 / 2 Position / Grommet Type

(Unit:mm)

DV3120 Single / Body Ported Type

DV3140 Single / Base Mounted Type

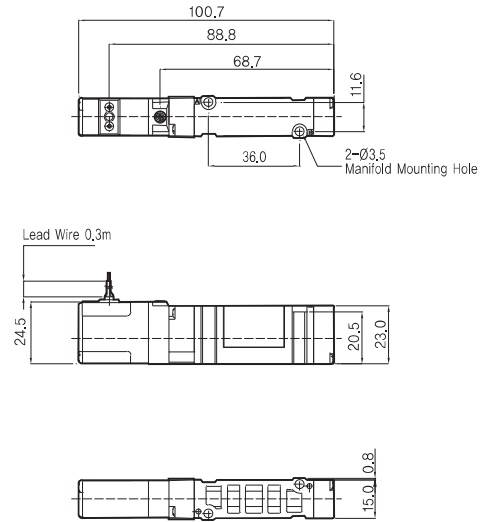
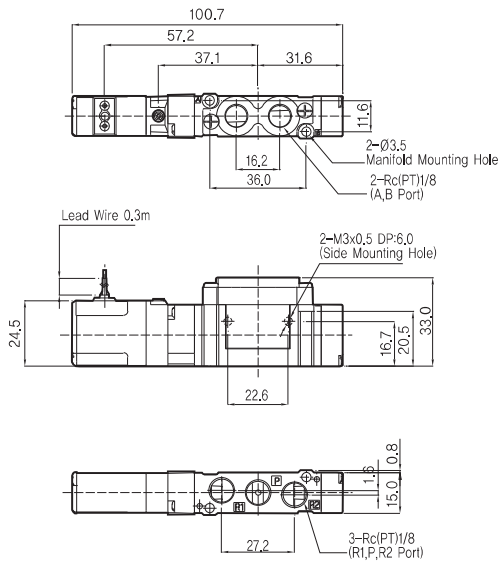

Series DV3000 / 2 Position / Din Terminal Type

(Unit:mm)

DV3120 Single / Body Ported Type

DV3140 Single / Base Mounted Type

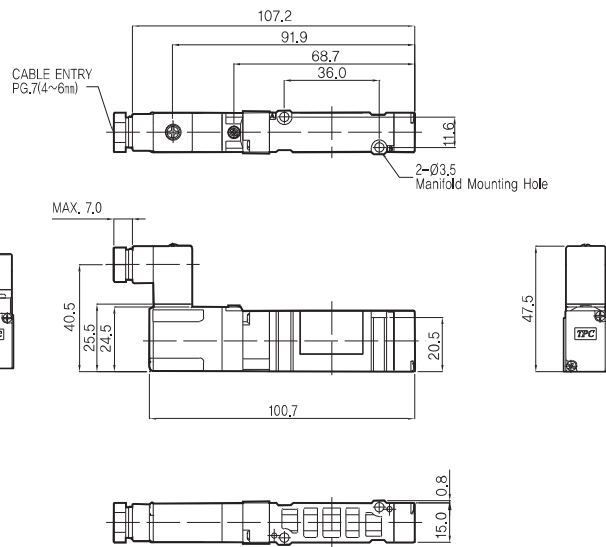
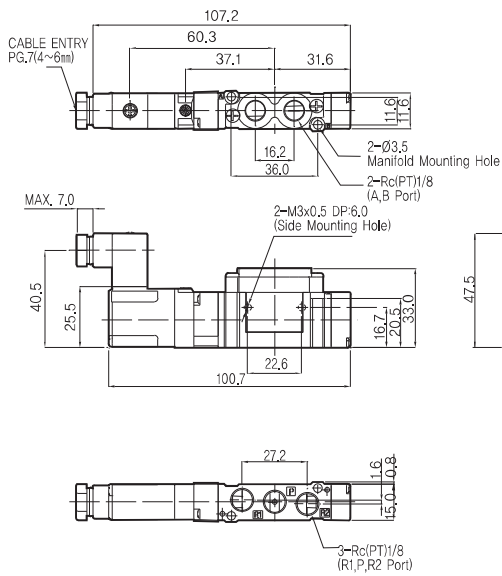

DW

DR100

DR200

RS1000,
2000

RS4000

SI UNIT

DV1000
DV3000
DV4000

DS300

DS3000

DS5000

DS2000

DS6000

DX1,DX2

DX1(2)R

DH

DP300
DP3000
DP5000

DM

DT220

Series DV3000

Series DV3000 / 2 Position / H: Horizontal Connector Type

(Unit: mm)

DV3220 Double / Body Ported Type

DV3240 Double / Base Mounted Type

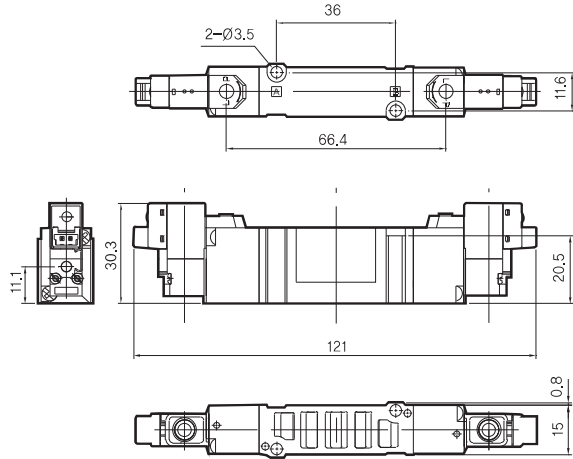
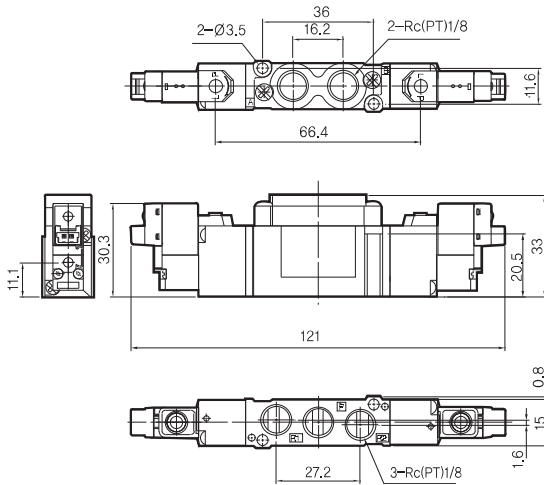

Series DV3000 / 2 Position / V: Vertical Connector Type

(Unit: mm)

DV3220 Double / Body Ported Type

DV3240 Double / Base Mounted Type

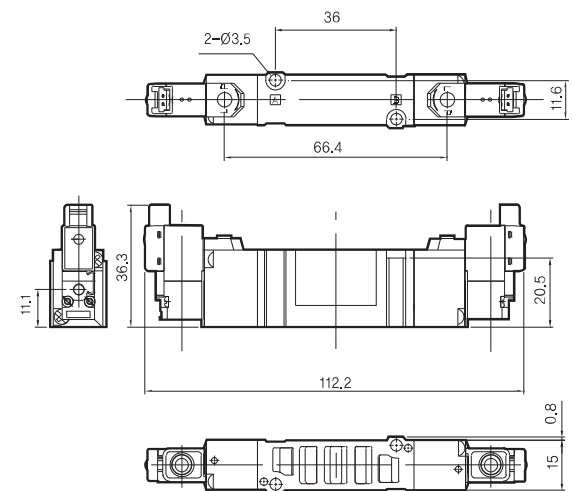
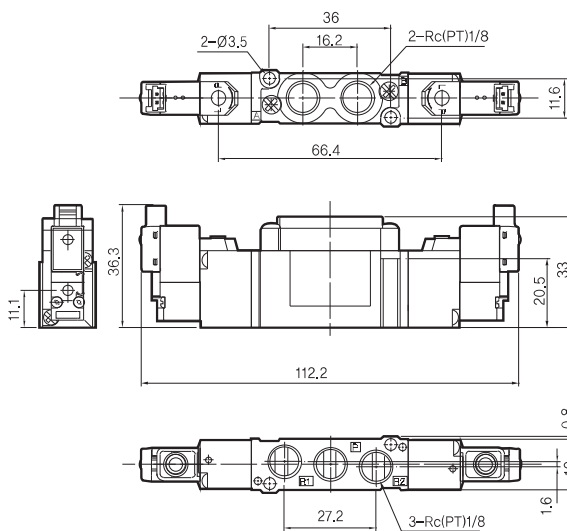

Series DV3000

Series DV3000 / 2 Position / Grommet Type

(Unit:mm)

DV3220 Double / Body Ported Type

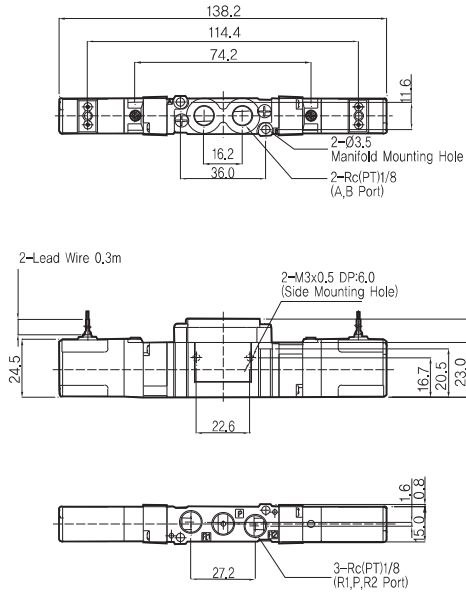

DV3240 Double / Base Mounted Type

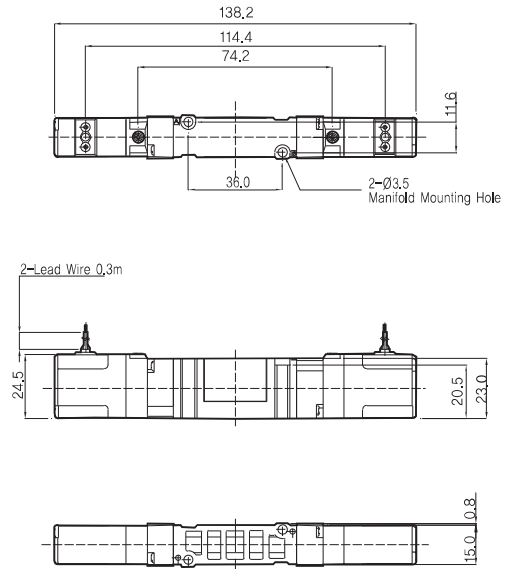

Series DV3000 / 2 Position / Din Terminal Type

(Unit:mm)

DV3220 Double / Body Ported Type

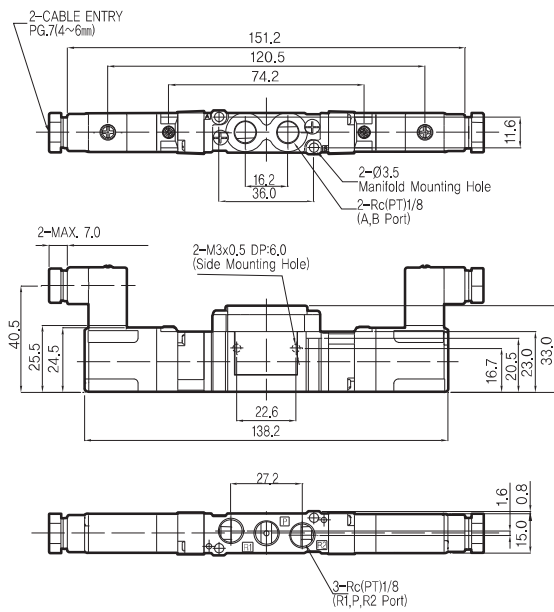

DV3240 Double / Base Mounted Type

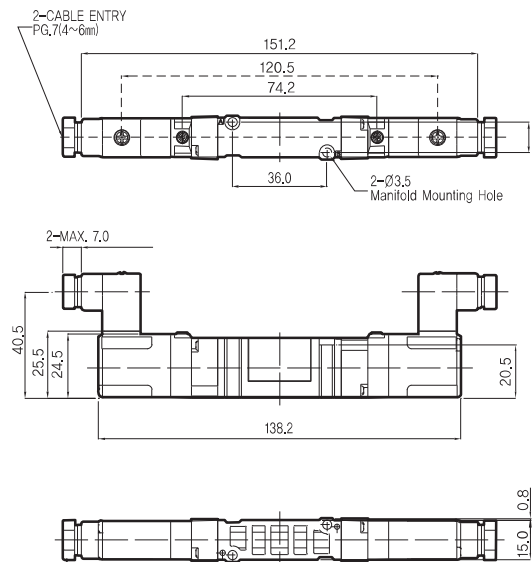

DW
DR100
DR200
RS1000, 2000
RS4000
SI UNIT
DV1000
DV3000
DV4000
DS300
DS3000
DS5000
DS2000
DS6000
DX1,DX2
DX1(2)R
DH
DP300
DP3000
DP5000
DM
DT220

Series DV3000

Series DV3000 / 3 Position / H: Horizontal Connector Type

(Unit: mm)

DV3320/3420/3520 3 Position / Body Ported Type

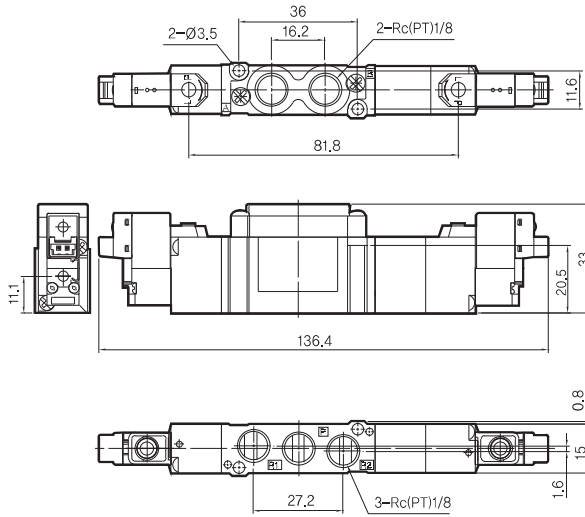

DV3340/3440/3540 3 Position / Base Mounted Type

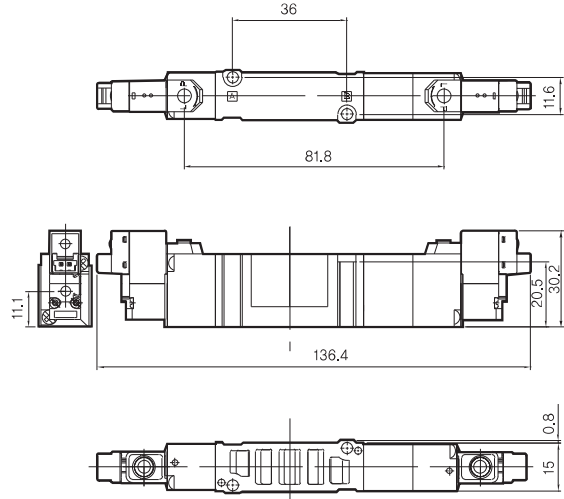

Series DV3000 / 3 Position / V: Vertical Connector Type

(Unit: mm)

DV3320/3420/3520 3 Position / Body Ported Type

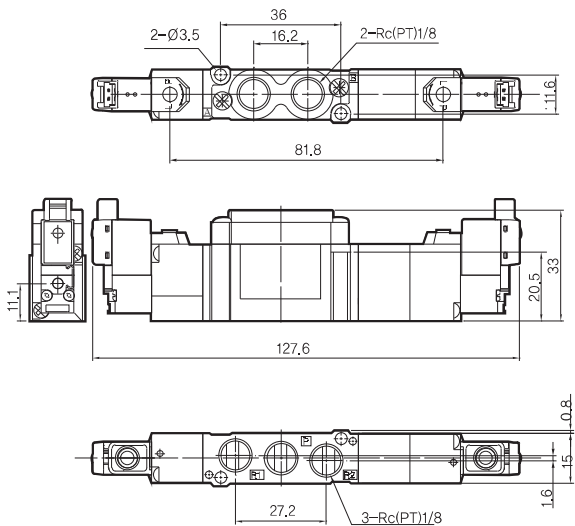

DV3340/3440/3540 3 Position / Base Mounted Type

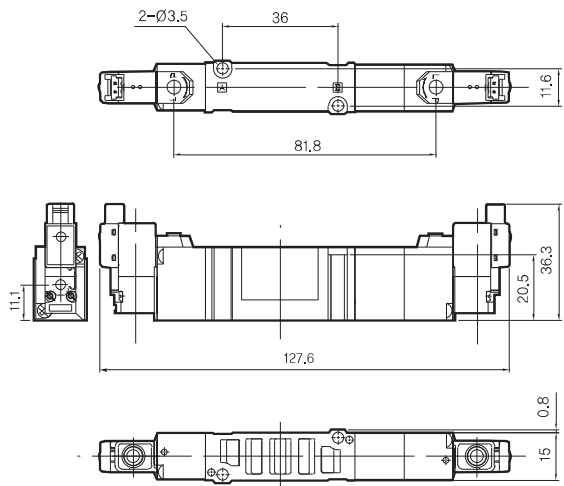

Series DV3000

Series DV3000 / 3 Position / Grommet Type

(Unit:mm)

DV3320/3420/3520 3 Position / Body Ported Type

DV3340/3440/3540 3 Position / Base Mounted Type

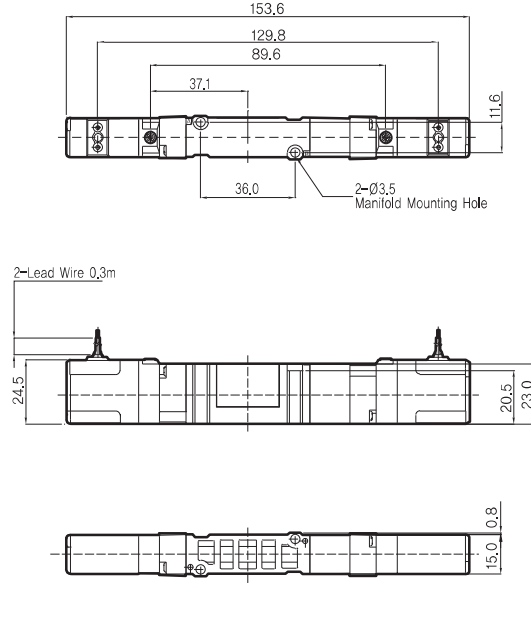
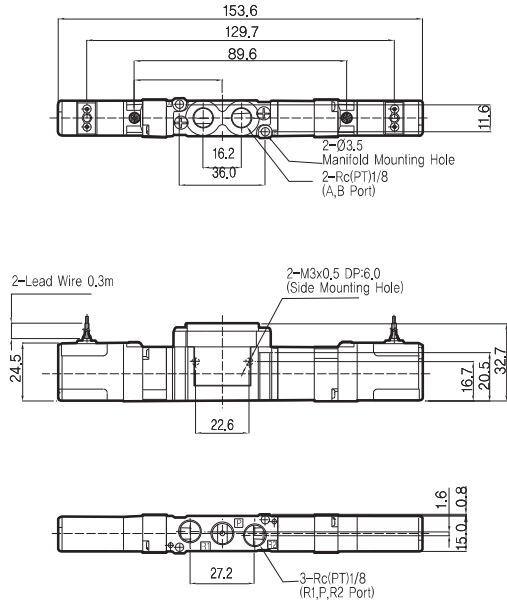

Series DV3000 / 3 Position / Din Terminal Type

(Unit:mm)

DV3320/3420/3520 3 Position / Body Ported Type

DV3340/3440/3540 3 Position / Base Mounted Type

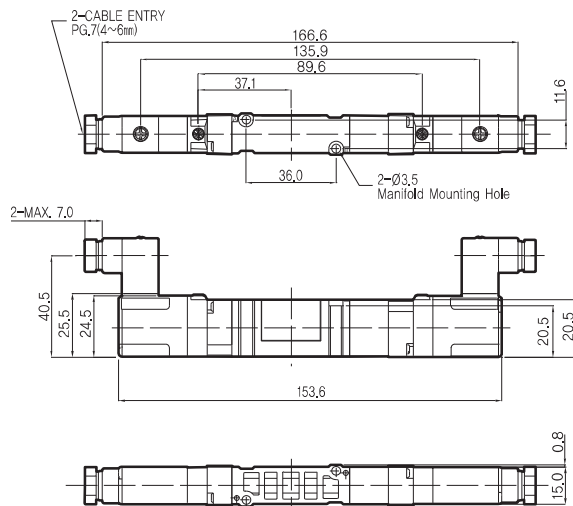
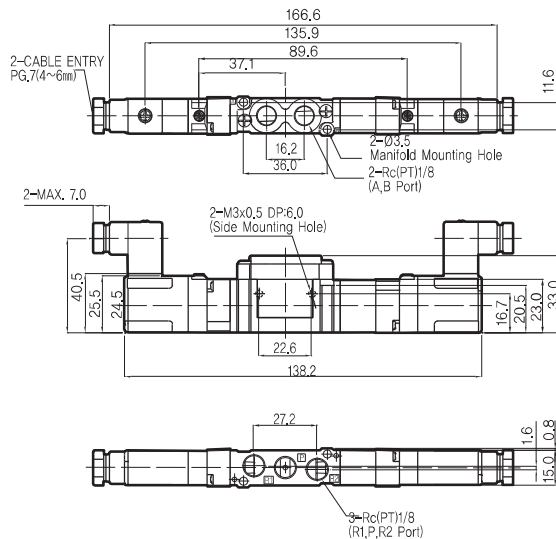

DW
DR100
DR200
RS1000, 2000
RS4000
SI UNIT
DV1000 DV3000 DV4000
DS300
DS3000
DS5000
DS2000
DS6000
DX1,DX2
DX1(2)R
DH
DP300 DP3000 DP5000
DM
DT220

Series DV3000

Manifold Dimensions / Series DV3000 Body Ported / H: Horizontal Connector Type

(Unit: mm)

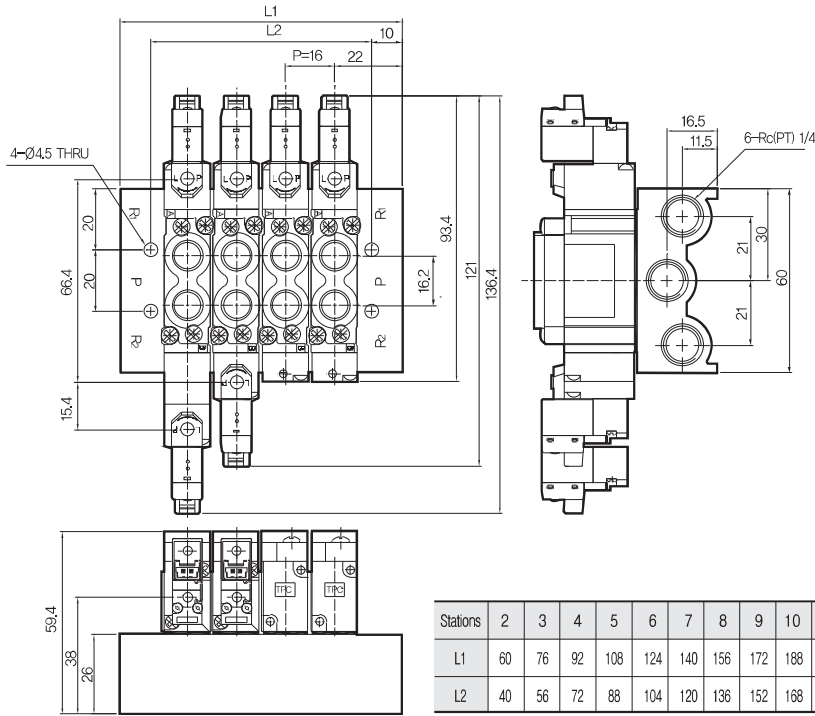

How To Order

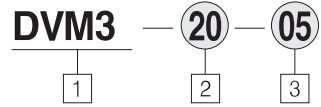

- 1 DV3000 Manifold
- 2 Body Ported Type
- 3 Stations (2~20)

Stations	2	3	4	5	6	7	8	9	10	11	12	13	14	15	16	17	18	19	20
L1	60	76	92	108	124	140	156	172	188	204	220	236	252	268	284	300	316	332	348
L2	40	56	72	88	104	120	136	152	168	184	200	216	232	248	264	280	296	312	328

(mm)

Manifold Dimensions / Series DV3000 Base Mounted / H: Horizontal Connector Type

(Unit: mm)

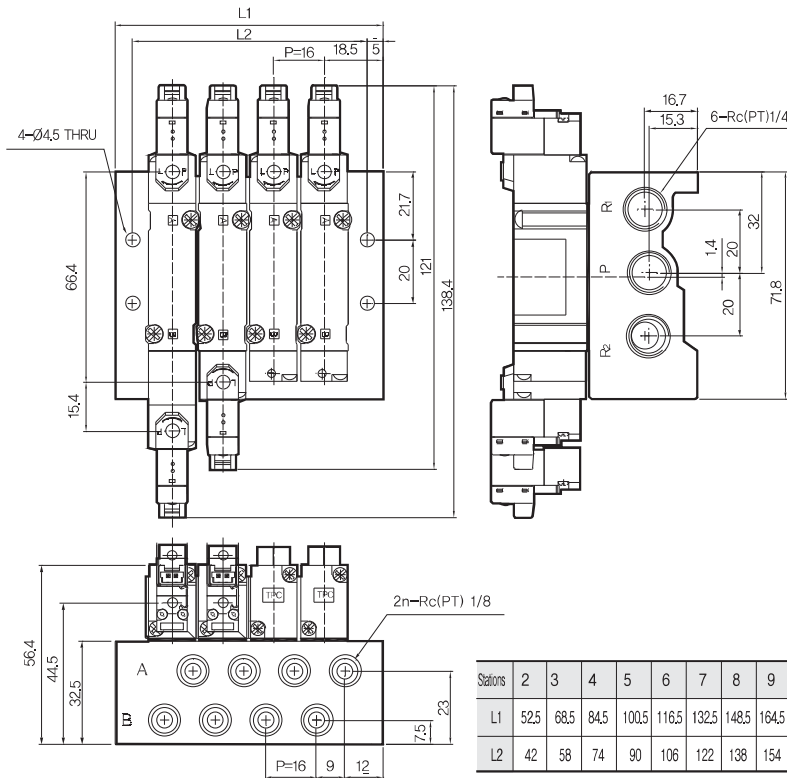

How To Order

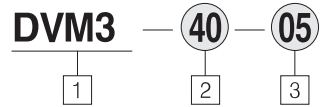

- 1 DV3000 Manifold
- 2 Base Mounted Type
- 3 Stations (2~20)

Stations	2	3	4	5	6	7	8	9	10	11	12	13	14	15	16	17	18	19	20
L1	52.5	68.5	84.5	100.5	116.5	132.5	148.5	164.5	180.5	196.5	212.5	228.5	244.5	260.5	276.5	292.5	308.5	324.5	340.5
L2	42	58	74	90	106	122	138	154	170	188	202	218	234	250	266	282	298	314	330

(mm)

Series DV3000

Manifold Dimensions / Series DV3000 Body Ported / V: Vertical Connector Type

(Unit: mm)

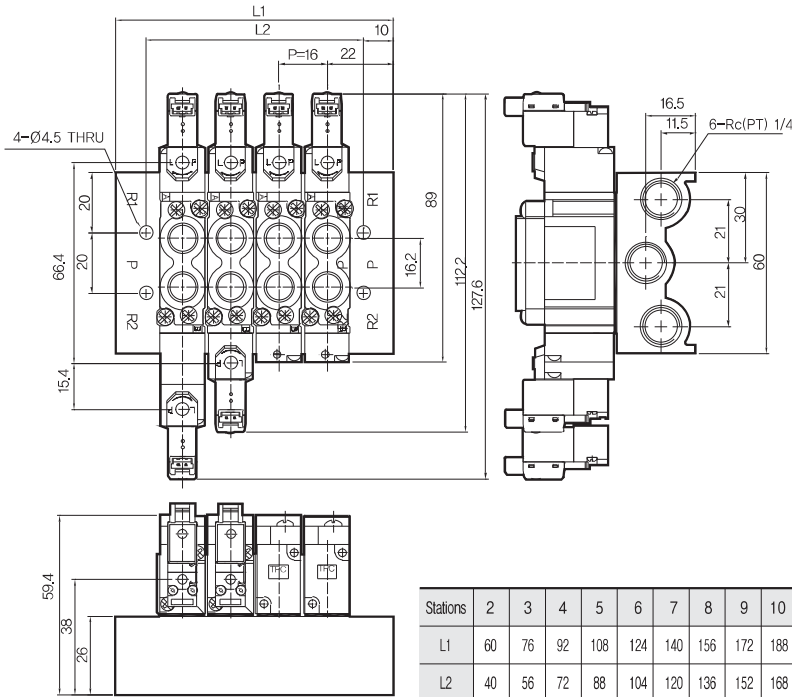

How To Order

DVM3 — **20** — **05**

1 2 3

1 DV3000 Manifold
2 Body Ported Type
3 Stations (2~20)

Stations	2	3	4	5	6	7	8	9	10	11	12	13	14	15	16	17	18	19	20
L1	60	76	92	108	124	140	156	172	188	204	220	236	252	268	284	300	316	332	348
L2	40	56	72	88	104	120	136	152	168	184	200	216	232	248	264	280	296	312	328

Manifold Dimensions / Series DV3000 Base Mounted / V: Vertical Connector Type

(Unit: mm)

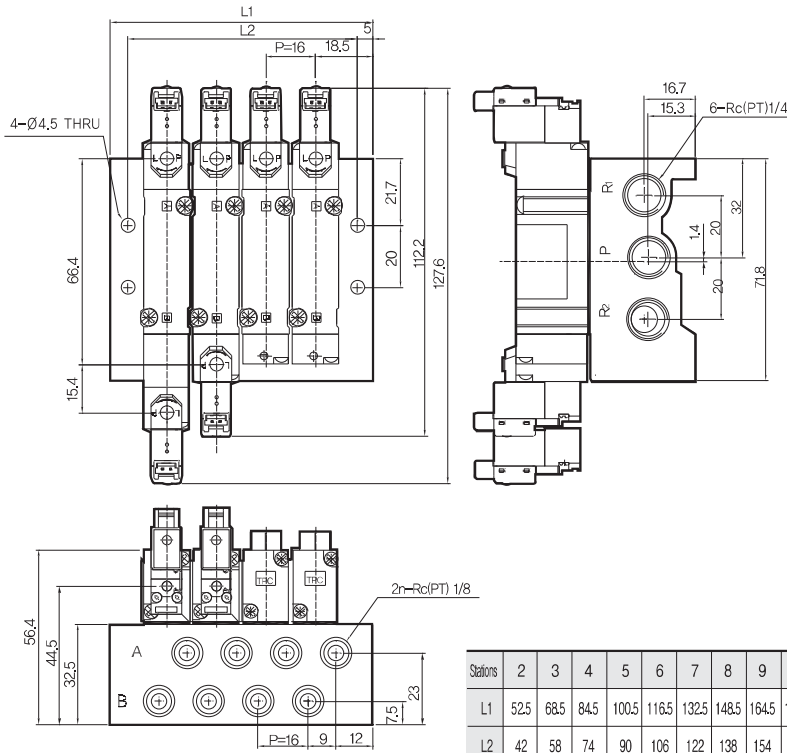

How To Order

DVM3 — **40** — **05**

1 2 3

1 DV3000 Manifold
2 Base Mounted Type
3 Stations (2~20)

Stations	2	3	4	5	6	7	8	9	10	11	12	13	14	15	16	17	18	19	20
L1	52.5	68.5	84.5	100.5	116.5	132.5	148.5	164.5	180.5	196.5	212.5	228.5	244.5	260.5	276.5	292.5	308.5	324.5	340.5
L2	42	58	74	90	106	122	138	154	170	188	202	218	234	250	266	282	298	314	330

- DW
- DR100
- DR200
- RS1000, 2000
- RS4000
- SI UNIT
- DV1000
- DV3000
- DV4000
- DS300
- DS3000
- DS5000
- DS2000
- DS6000
- DX1,DX2
- DX1(2)R
- DH
- DP300
- DP3000
- DP5000
- DM
- DT220

Series DV3000

Manifold Dimensions / Series DV3000 Body Ported / Din Terminal Type

(Unit:mm)

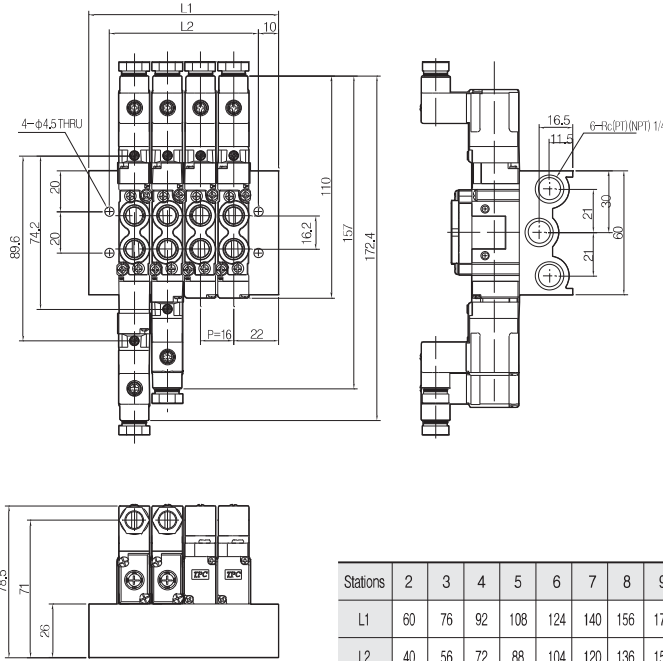

How To Order

DVM3 — **20** — **05**

1 2 3

- 1 DV3000 Manifold
- 2 Body Ported Type
- 3 Stations (2~20)

Manifold Dimensions / Series DV3000 Base Mounted / Din Terminal Type

(Unit:mm)

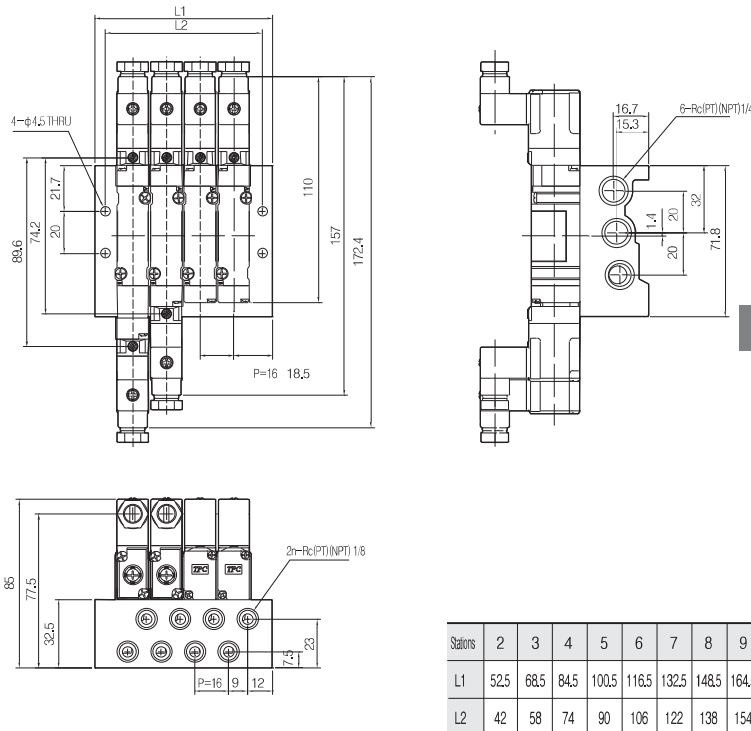

How To Order

DVM3 — **40** — **05**

1 2 3

- 1 DV3000 Manifold
- 2 Base Mounted Type
- 3 Stations (2~20)

- DW
- DR100
- DR200
- RS1000, 2000
- RS4000
- SI UNIT
- DV1000, DV3000, DV4000
- DS300
- DS3000
- DS5000
- DS2000
- DS6000
- DX1,DX2
- DX1(2)R
- DH
- DP300, DP3000, DP5000
- DM
- DT220

Series DV4000

Series DV4000 / 2 Position / H : Horizontal Connector Type

(Unit:mm)

DV4120 Single / Fitting Included Dimension Drawing(Body Ported Type)

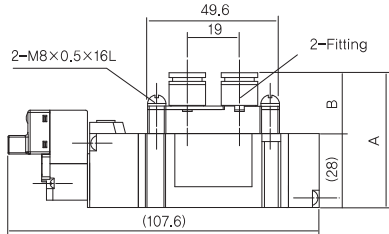

Series	Applicable Fitting Size	A	B	Note
DV4000	Ø8	54.1	26.1	
	Ø10	55.1	27.1	

DV4120 Single / Body Ported Type

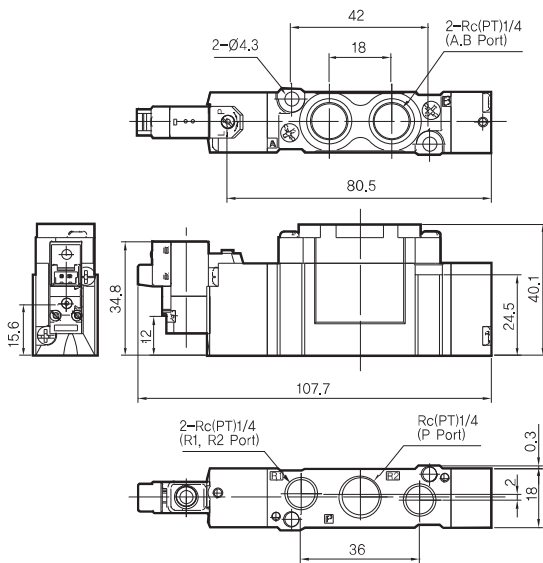

DV4140 Single / Base Mounted Type

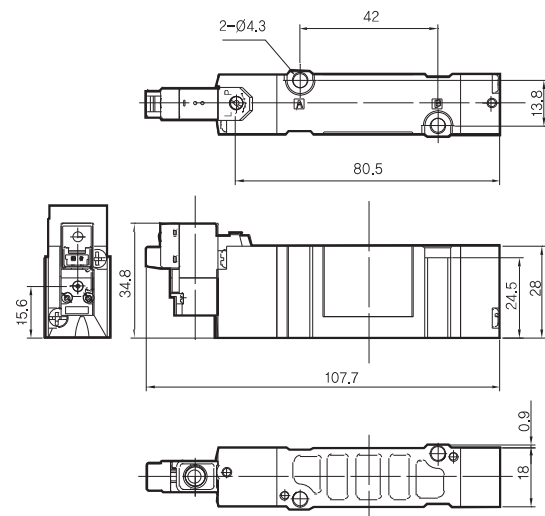

Series DV4000 / 2 Position / V : Vertical Connector Type

(Unit:mm)

DV4120 Single / Body Ported Type

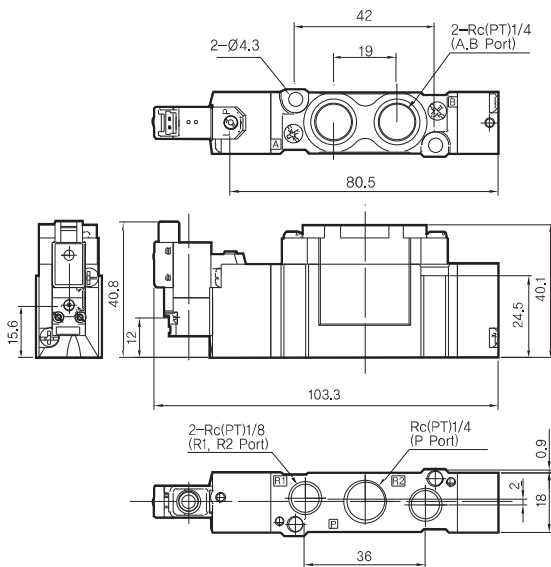

DV4140 Single / Base Mounted Type

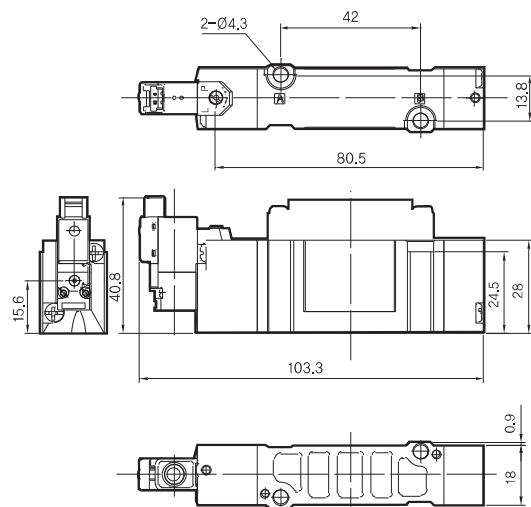

Series DV4000

Series DV4000 / 2 Position / H: Horizontal Connector Type

(Unit:mm)

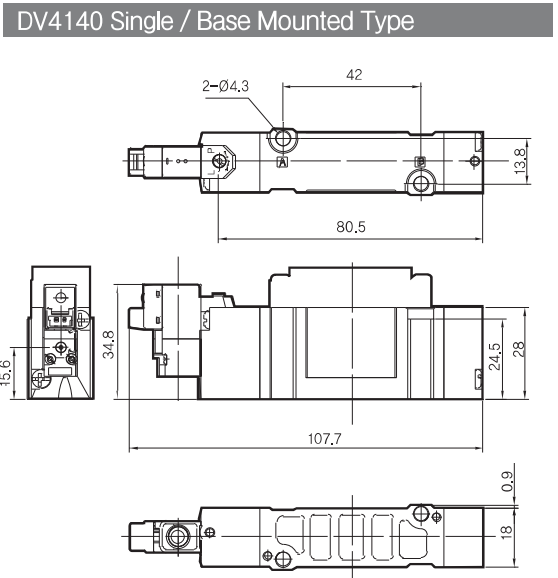
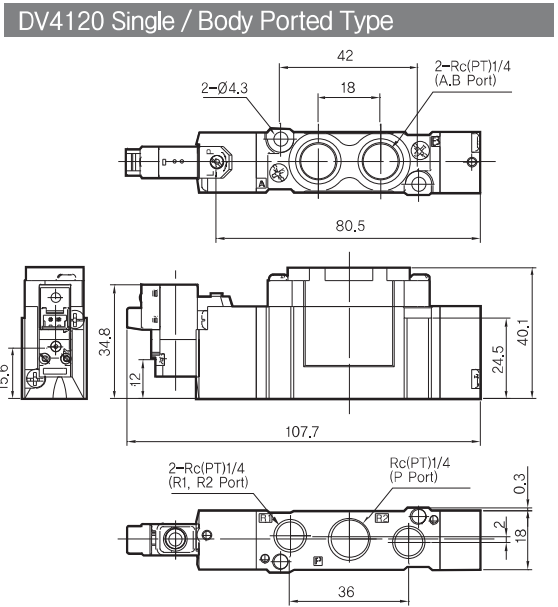

Series DV4000 / 2 Position / V: Vertical Connector Type

(Unit:mm)

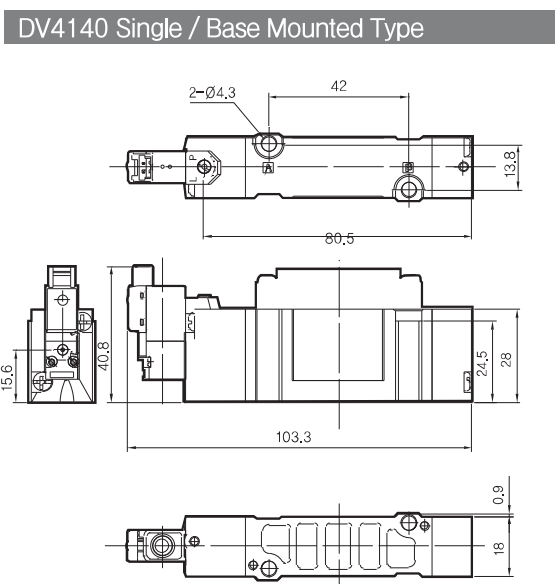
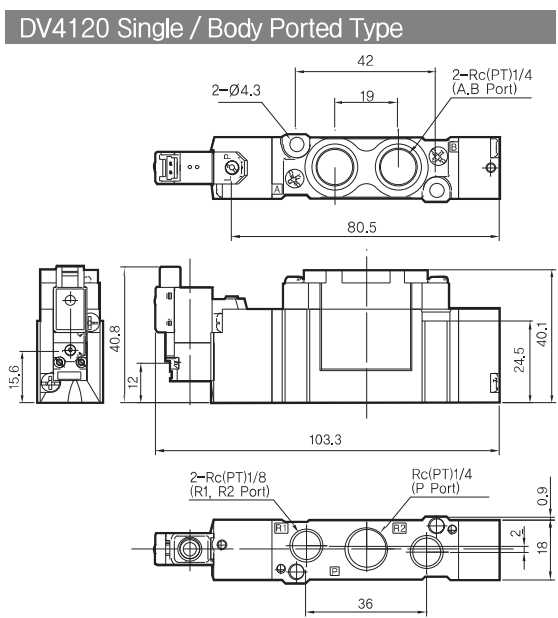

- DW
- DR100
- DR200
- RS1000, 2000
- RS4000
- SI UNIT
- DV1000**
- DV3000**
- DV4000**
- DS300
- DS3000
- DS5000
- DS2000
- DS6000
- DX1,DX2
- DX1(2)R
- DH
- DP300
- DP3000
- DP5000
- DM
- DT220

Series DV4000

Series DV4000 / 2 Position / Grommet Type

(Unit:mm)

DV4120 Single / Body Ported Type

DV4140 Single / Base Mounted Type

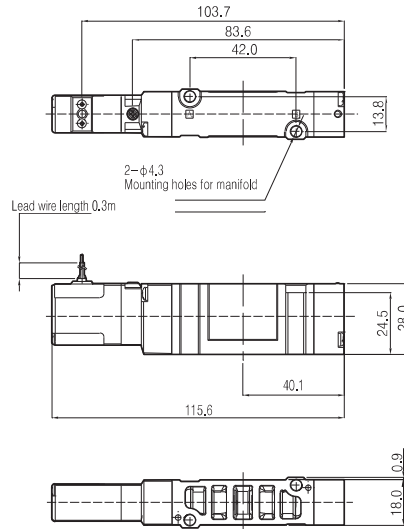
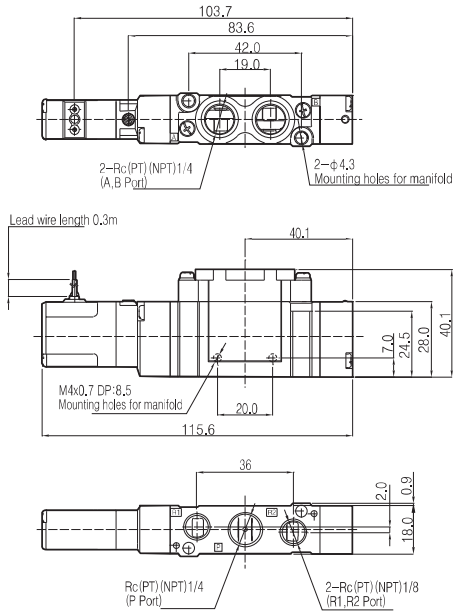

Series DV4000 / 2 Position / Din Terminal Type

(Unit:mm)

DV4120 Single / Body Ported Type

DV4140 Single / Base Mounted Type

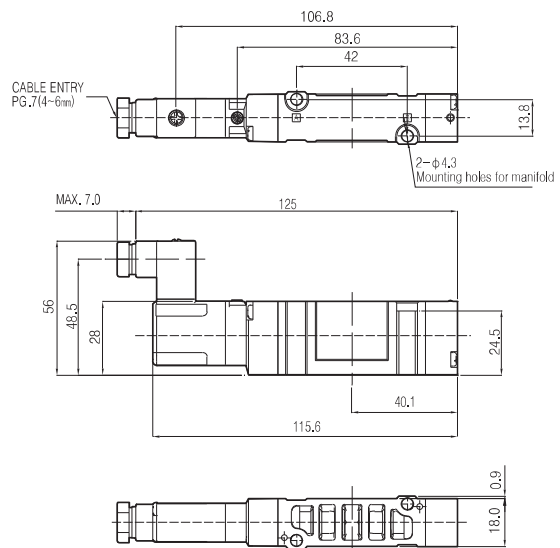
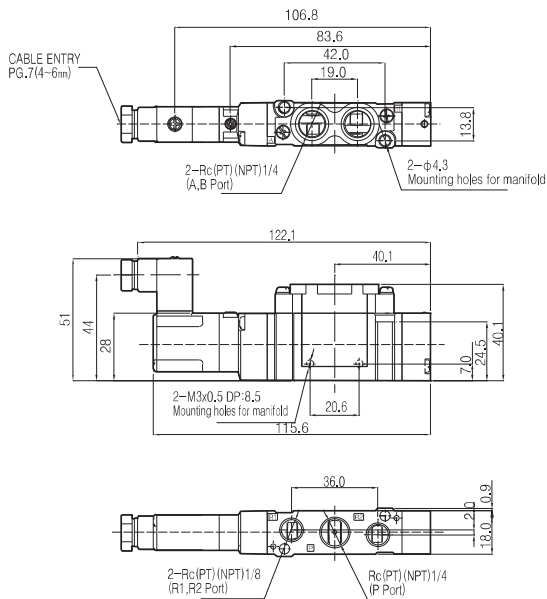

Series DV4000

Series DV4000 / 2 Position / H: Horizontal Connector Type

(Unit:mm)

DV4220 Double / Body Ported Type

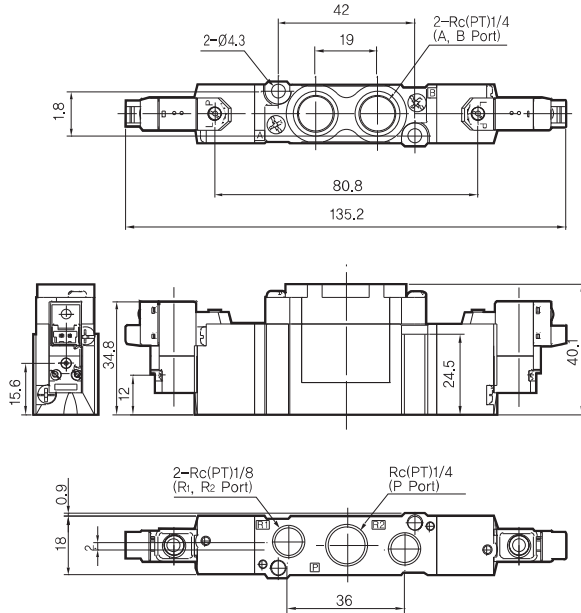

DV4240 Double / Base Mounted Type

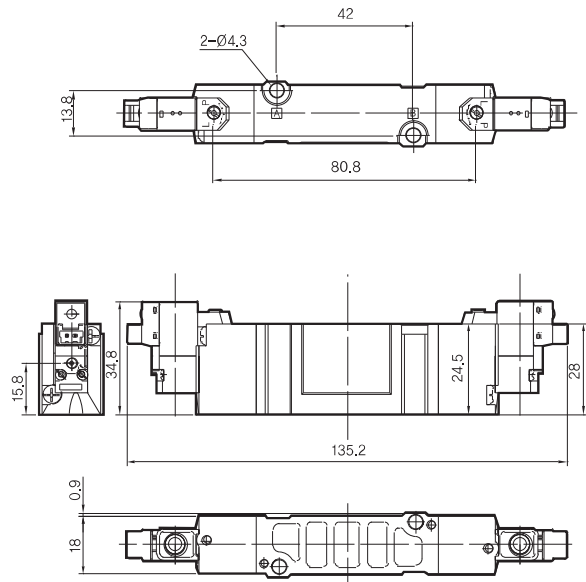

Series DV4000 / 2 Position / V: Vertical Connector Type

(Unit:mm)

DV4220 Double / Body Ported Type

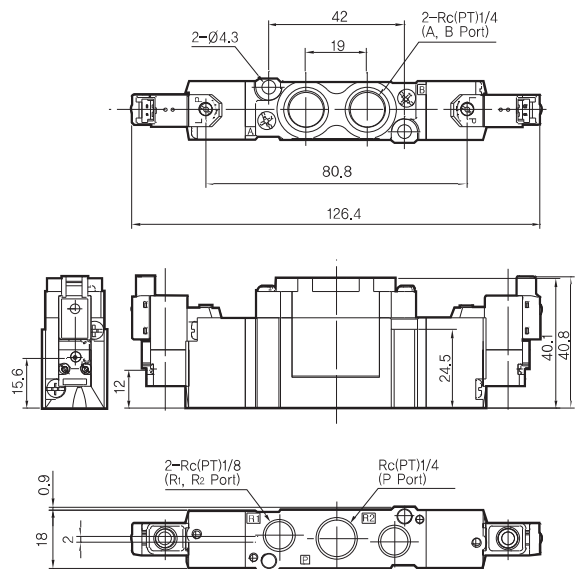

DV4240 Double / Base Mounted Type

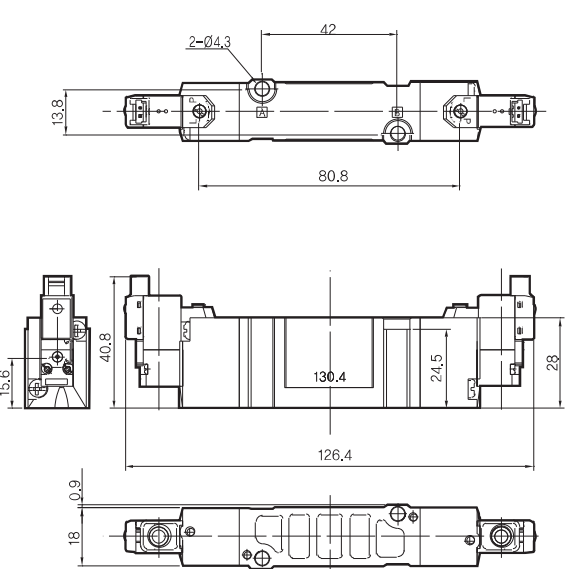

DW

DR100

DR200

RS1000,
2000

RS4000

SI UNIT

DV1000
DV3000
DV4000

DS300

DS3000

DS5000

DS2000

DS6000

DX1,DX2

DX1(2)R

DH

DP300
DP3000
DP5000

DM

DT220

Series DV4000

Series DV4000 / 2 Position / Grommet Type

(Unit:mm)

DV4220 Double / Body Ported Type

DV4240 Double / Base Mounted Type

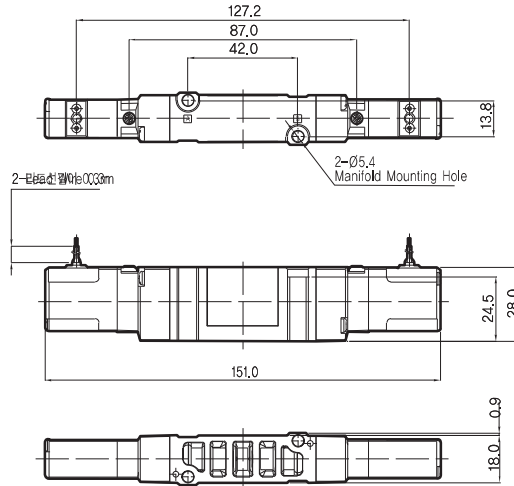
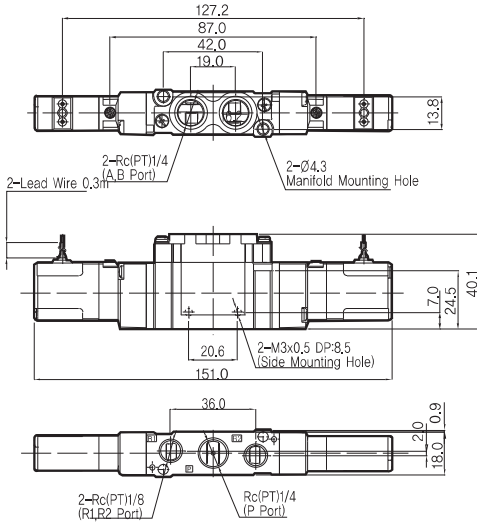

Series DV4000 / 2 Position / Din Terminal Type

(Unit:mm)

DV4220 Double / Body Ported Type

DV4240 Double / Base Mounted Type

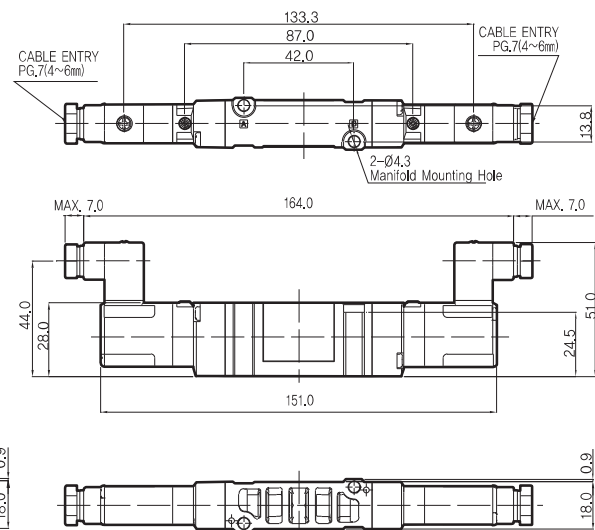
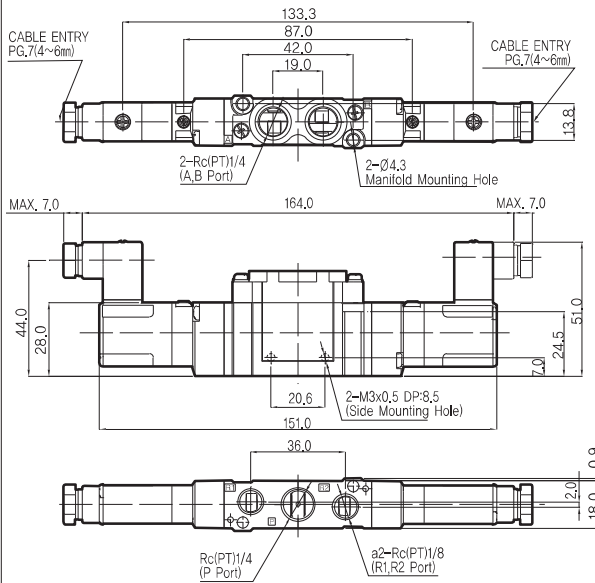

Series DV4000

Series DV4000 / 3 Position / H: Horizontal Connector Type

(Unit:mm)

DV4320/4420/4520 3 Position / Body Ported Type

DV4340/4440/4540 3 Position / Base Mounted Type

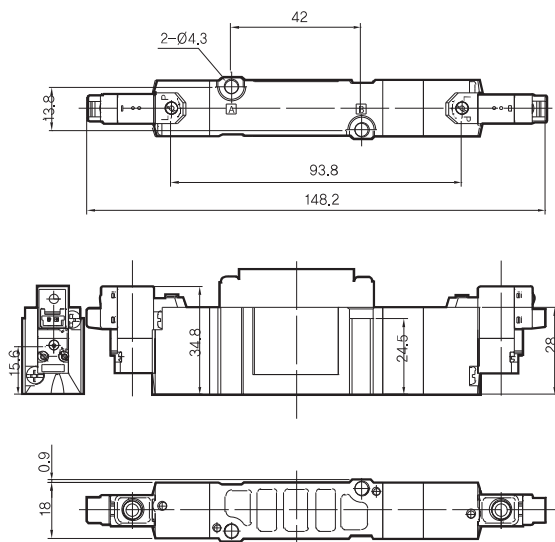
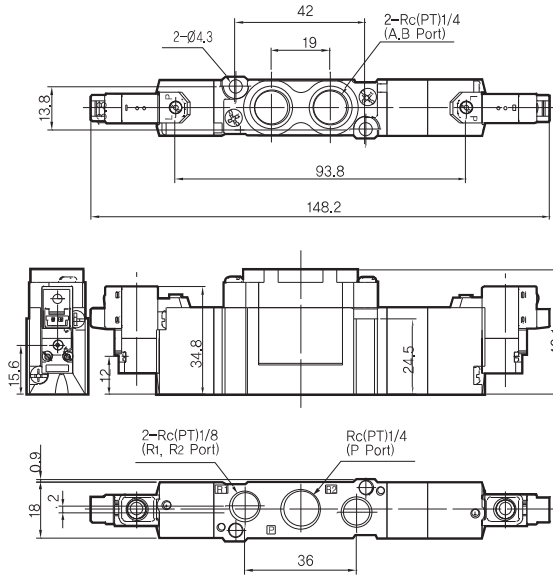

Series DV4000 / 3 Position / V: Vertical Connector Type

(Unit:mm)

DV4320/4420/4520 3 Position / Body Ported Type

DV4340/4440/4540 3 Position / Base Mounted Type

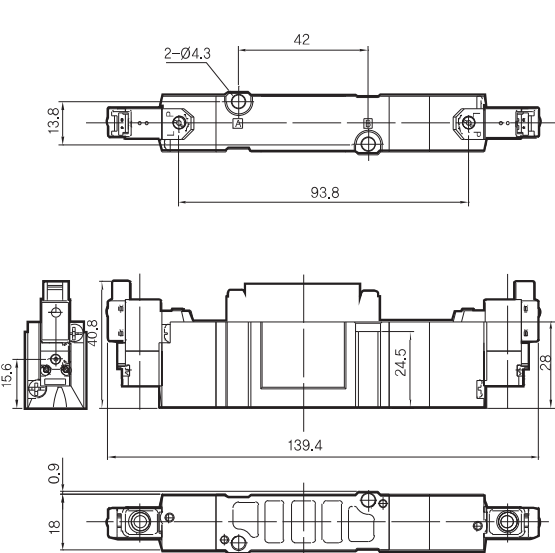
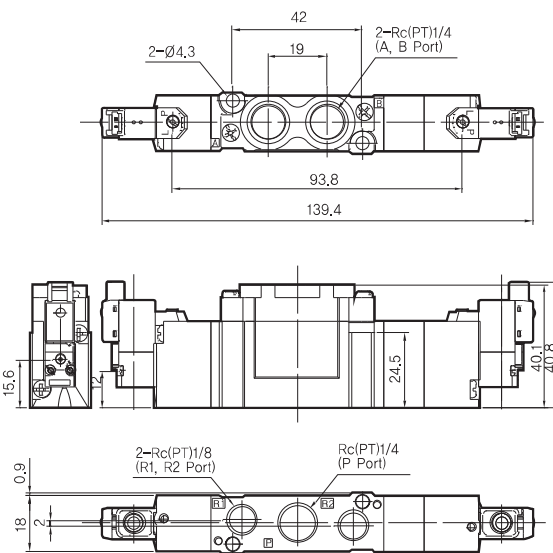

DW

DR100

DR200

RS1000,
2000

RS4000

SI UNIT

DV1000
DV3000
DV4000

DS300

DS3000

DS5000

DS2000

DS6000

DX1,DX2

DX1(2)R

DH

DP300
DP3000
DP5000

DM

DT220

Series DV4000

Series DV4000 / 3 Position / Grommet Type

(Unit: mm)

DV4320/4420/4520 3 Position / Body Ported Type

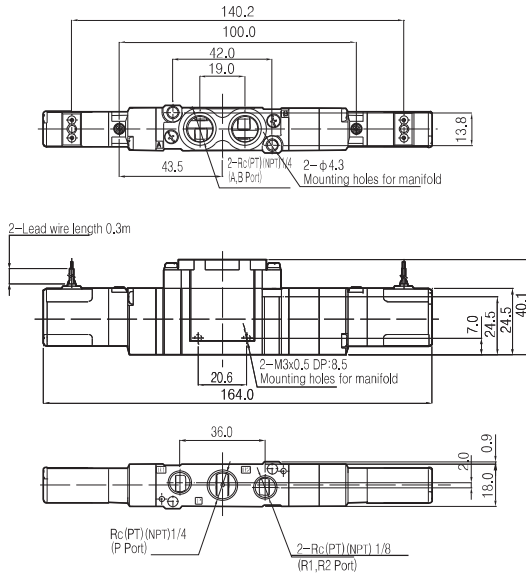

DV4340/4440/4540 3 Position / Base Mounted Type

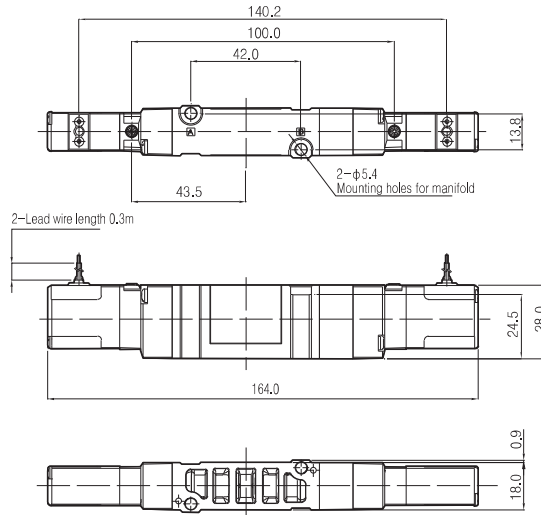

Series DV4000 / 3 Position / Din Terminal Type

(Unit: mm)

DV4320/4420/4520 3 Position / Body Ported Type

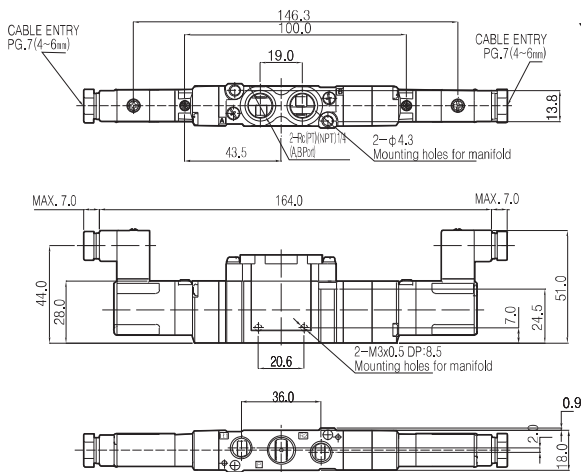

DV4340/4440/4540 3 Position / Base Mounted Type

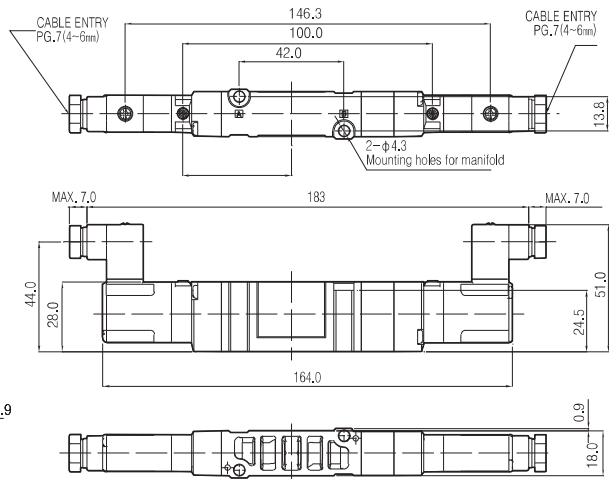

Series DV4000

Manifold Dimensions / Series DV4000 Body Ported / H: Horizontal Connector Type

(Unit:mm)

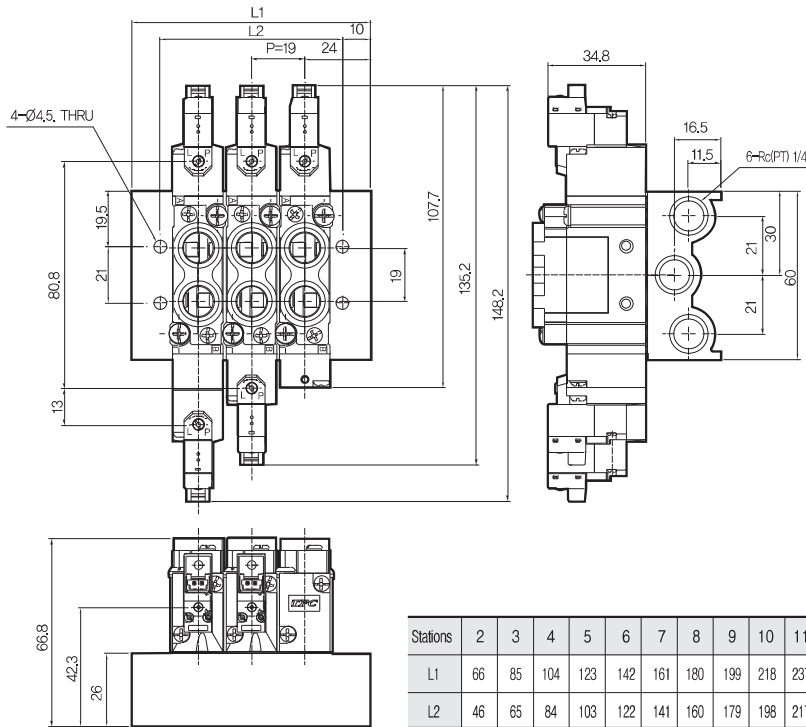

How To Order

DVM4 — **20** — **05**

1 2 3

- 1 DV4000 Manifold
- 2 Body Ported Type
- 3 Stations (2~20)

Stations	2	3	4	5	6	7	8	9	10	11	12	13	14	15	16	17	18	19	20
L1	66	85	104	123	142	161	180	199	218	237	256	275	294	313	332	351	370	389	408
L2	46	65	84	103	122	141	160	179	198	217	236	255	274	293	312	331	350	369	388

Manifld Dimensions / Series DV4000 Base Mounted / H: Horizontal Connector Type

(Unit:mm)

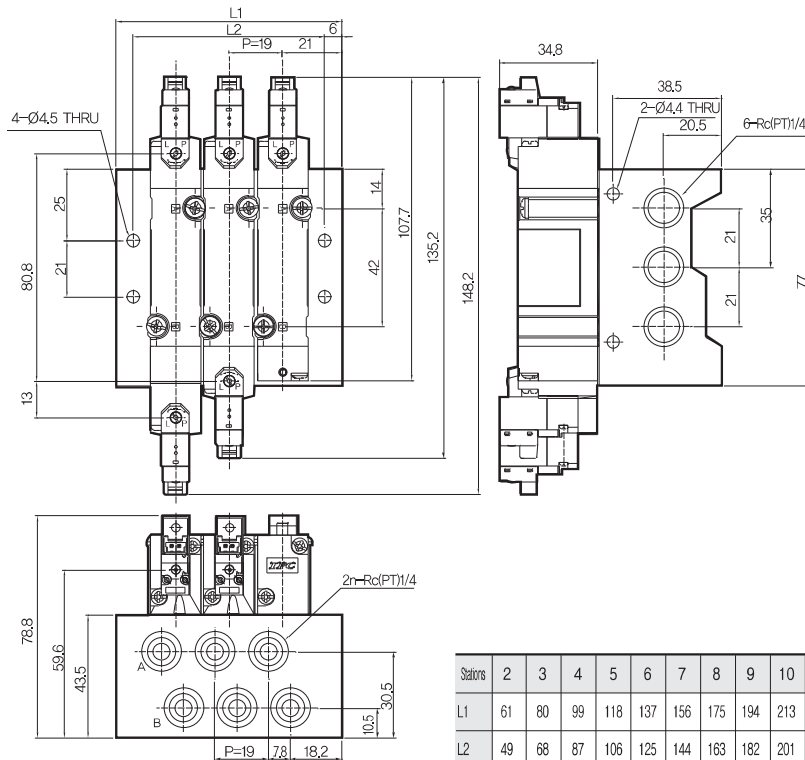

How To Order

DVM4 — **40** — **05**

1 2 3

- 1 DV4000 Manifold
- 2 Base Mounted Type
- 3 Stations (2~20)

Stations	2	3	4	5	6	7	8	9	10	11	12	13	14	15	16	17	18	19	20
L1	61	80	99	118	137	156	175	194	213	232	251	270	289	308	327	346	365	384	403
L2	49	68	87	106	125	144	163	182	201	220	239	258	277	296	315	334	353	372	391

DW

DR100

DR200

RS1000,
2000

RS4000

SI UNIT

DV1000
DV3000
DV4000

DS300

DS3000

DS5000

DS2000

DS6000

DX1,DX2

DX1(2)R

DH

DP300
DP3000
DP5000

DM

DT220

Series DV4000

Manifold Dimensions / Series DV4000 Body Ported / V: Vertical Connector Type

(Unit:mm)

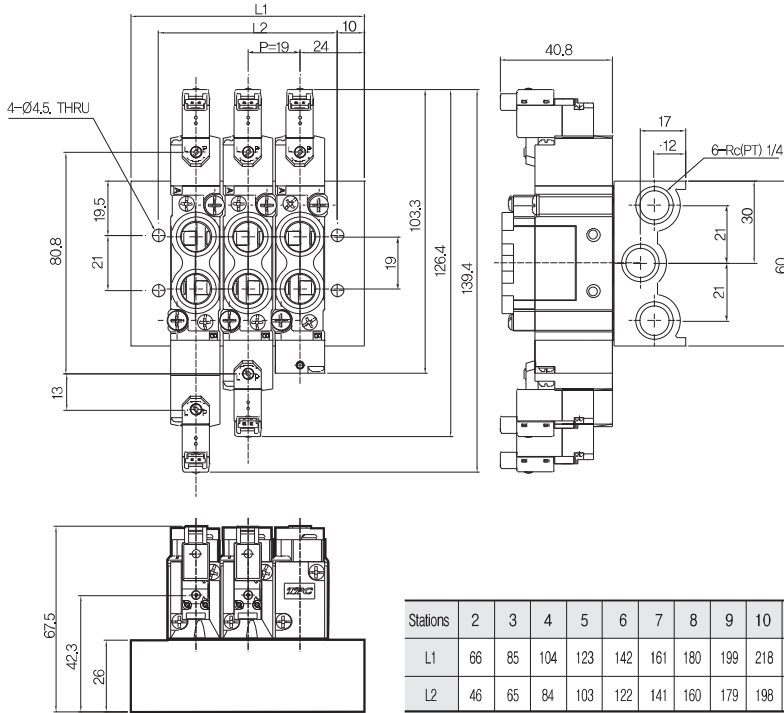

How To Order

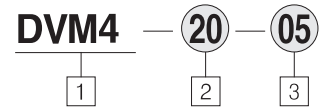

- 1 DV4000 Manifold
- 2 Body Ported Type
- 3 Stations (2~20)

Stations	2	3	4	5	6	7	8	9	10	11	12	13	14	15	16	17	18	19	20
L1	66	85	104	123	142	161	180	199	218	237	256	275	294	313	332	351	370	389	408
L2	46	65	84	103	122	141	160	179	198	217	236	255	274	293	312	331	350	369	388

Manifold Dimensions / Series DV4000 Base Mounted / V: Vertical Connector Type

(Unit:mm)

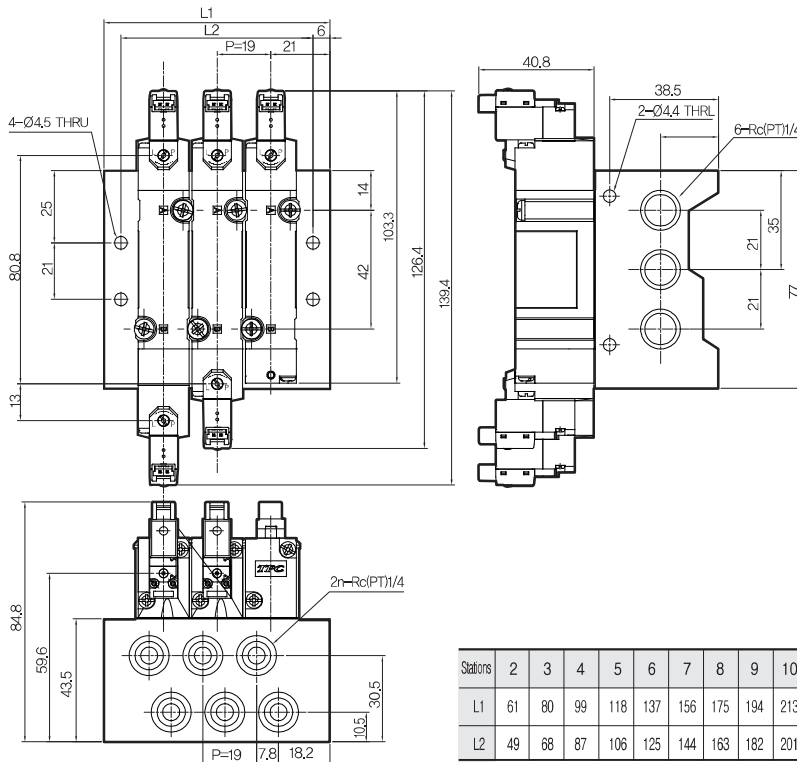

How To Order

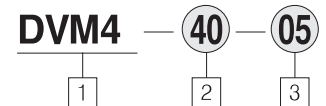

- 1 DV4000 Manifold
- 2 Base Mounted Type
- 3 Stations (2~20)

Stations	2	3	4	5	6	7	8	9	10	11	12	13	14	15	16	17	18	19	20
L1	61	80	99	118	137	156	175	194	213	232	251	270	289	308	327	346	365	384	403
L2	49	68	87	106	125	144	163	182	201	220	239	258	277	296	315	334	353	372	391

Series DV4000

Manifold Dimensions / Series DV4000 Body Ported : Grommet Type

(Unit:mm)

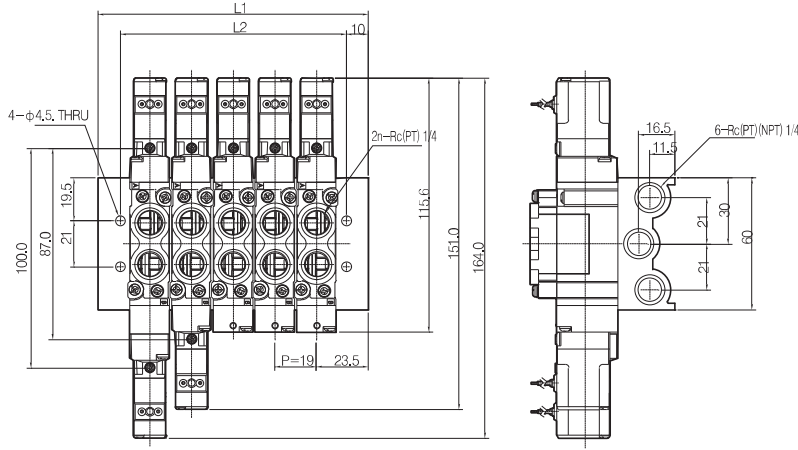

How To Order

DVM4 — **20** — **05**

1

2

3

- 1 DV4000 Manifold
- 2 Body Ported Type
- 3 Stations (2~20)

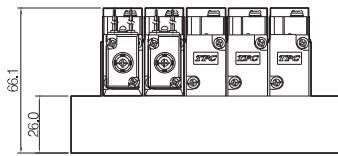

Stations	2	3	4	5	6	7	8	9	10	11	12	13	14	15	16	17	18	19	20
L1	66	85	104	123	142	161	180	199	218	237	256	275	294	313	332	351	370	389	408
L2	46	65	84	103	122	141	160	179	198	217	236	255	274	293	312	331	350	369	388

Manifold Dimensions / Series DV4000 Base Mounted : Grommet Type

(Unit:mm)

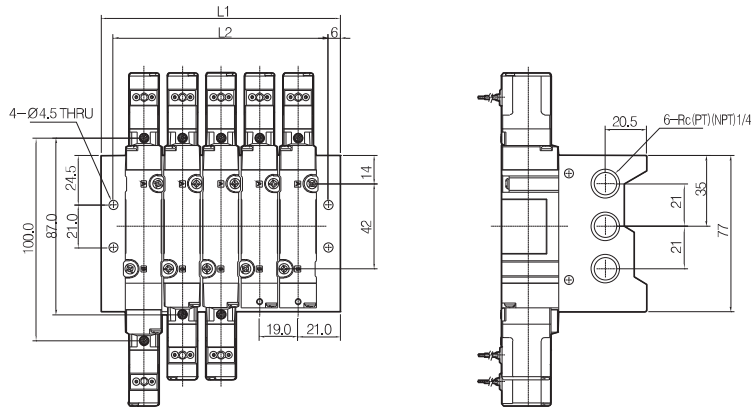

How To Order

DVM4 — **40** — **05**

1

2

3

- 1 DV4000 Manifold
- 2 Base Mounted Type
- 3 Stations (2~20)

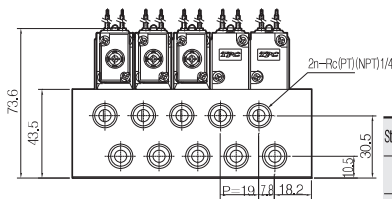

Stations	2	3	4	5	6	7	8	9	10	11	12	13	14	15	16	17	18	19	20
L1	61	80	99	118	137	156	175	194	213	232	251	270	289	308	327	346	365	384	403
L2	49	68	87	106	125	144	163	182	201	220	239	258	277	296	315	334	353	372	391

- DW
- DR100
- DR200
- RS1000, 2000
- RS4000
- SI UNIT
- DV1000
- DV3000
- DV4000
- DS300
- DS3000
- DS5000
- DS2000
- DS6000
- DX1,DX2
- DX1(2)R
- DH
- DP300
- DP3000
- DP5000
- DM
- DT220

Series DV4000

DV4000 Series Body Ported Manifold Dimensions / Din Terminal Type

(Unit: mm)

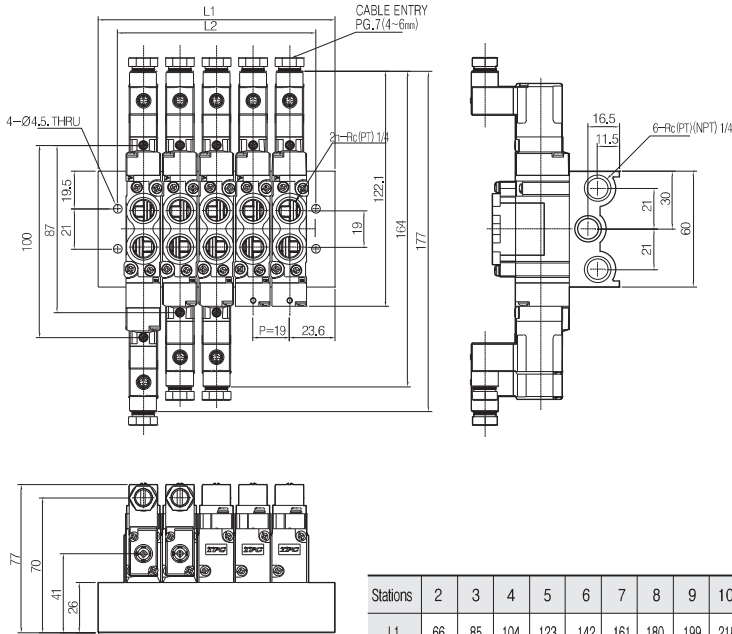

How To Order

- DVM4** — **20** — **05**
- 1 2 3
- 1 DV4000 Manifold
 - 2 Body Ported Type
 - 3 Stations (2~20)

Stations	2	3	4	5	6	7	8	9	10	11	12	13	14	15	16	17	18	19	20
L1	66	85	104	123	142	161	180	199	218	237	256	275	294	313	332	351	370	389	408
L2	46	65	84	103	122	141	160	179	198	217	236	255	274	293	312	331	350	369	388

DV4000 Series Base Mounted Manifold Dimensions / Din Terminal Type

(Unit: mm)

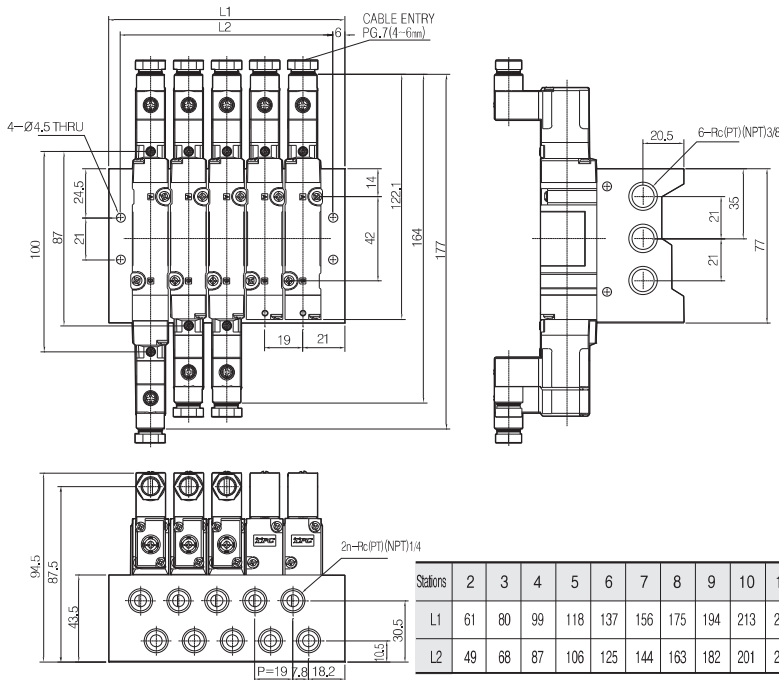

How To Order

- DVM4** — **40** — **05**
- 1 2 3
- 1 DV4000 Manifold
 - 2 Base Mounted Type
 - 3 Stations (2~20)

Stations	2	3	4	5	6	7	8	9	10	11	12	13	14	15	16	17	18	19	20
L1	61	80	99	118	137	156	175	194	213	232	251	270	289	308	327	346	365	384	403
L2	49	68	87	106	125	144	163	182	201	220	239	258	277	296	315	334	353	372	391

Series DV4000

Safety Instructions

These safety instructions are basically provided so as to prevent hazardous situations and/or equipment damage. These instructions indicate the level of potential hazard by labeling "Caution", "Warning" or "Danger". In order to achieve a desired safety, it is preferred to comply ISO 4414(Note1), KS B 6376(Note2), JIS B 8370(Note3) and other safety practices.

- ❗ **Danger** : There is a possibility of serious injury or loss of life in extreme.
- ❗ **Warning** : Operator error may cause serious injury or loss of life.
- ❗ **Caution** : Operator error may cause injury or equipment damage.

Note1) ISO4414 : Pneumatic fluid power—Recommendations for the application of equipment to transmission and control systems.

Note2) KS B 6376 : Pneumatic system axiom

Note3) JIS B 8370 : Pneumatic system axiom

❗ Warning

- In event that the product is to be used in any of the following conditions contact us:
 1. In event that conditions and environments beyond the given specifications, or if product is used outdoors,
 2. In the case of Installation on equipment in conjunction with atomic energy, railway, air navigation, vehicles, medical equipment, food and beverage, recreation equipment, emergency stop circuits, press applications, or safety equipment,
 3. In the case of an application provided with the possibility of having effects on people, property, or animals, requiring special safety analysis.
- It is preferred that the compatibility of pneumatic equipment is the responsibility of the person who designs the pneumatic system or decides its specifications.
Their compatibility with the specific pneumatic system must be based on specifications or after analysis and/or tests to meet your specific requirements because the products specified here are used in various operating conditions..
- Pneumatically operated machinery and equipment should be handled by only trained personnel.
If an operator is unfamiliar with it, compressed air can be dangerous. Trained and experienced operators are preferred to perform assembly, handling or repair of pneumatic systems.
- Service machinery/equipment or attempt to remove components until safety is confirmed should be avoided.
 1. After confirmation of safe locked -out control positions, it is preferred to perform inspection and maintenance of machinery/equipment.
 2. When equipment is to be removed, confirm the safety process as mentioned above. Cut the supply pressure for the equipment and exhaust all residual compressed air in the system,
 3. Be sure to take measures to prevent quick extensions of the cylinder piston rod etc, prior to machinery/equipment is re-started (Bleed air into the system gradually to create back-pressure.)

DW

DR100

DR200

RS1000,
2000

RS4000

SI UNIT

DV1000
DV3000
DV4000

DS300

DS3000

DS5000

DS2000

DS6000

DX1,DX2

DX1(2)R

DH

DP300
DP3000
DP5000

DM

DT220

Series DV4000

Precautions

Be sure to read before handling.
Refer to safety instructions and common precautions.

Caution

Manual operation

[The Push-turn Lock method driver operation]

While pushing the manual button turn to the arrow direction. If you do not turn and push you can use the Non-lock Push method to operate. When using a driver you can use a watch driver to easily turn. When removing the Lock you can turn to the opposite direction of the arrow. If you press too hard you will damage the valve.

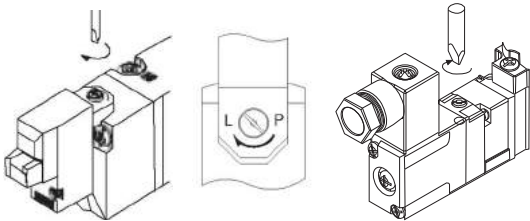

Caution) When activating automatically have the manual button on the Lock stage and make sure to activate after removing the Lock.

[Non-lock Push method manual operation]

Using the Solenoid coil side manual operation press lightly on the manual button under the coil connector with a driver as seen below.

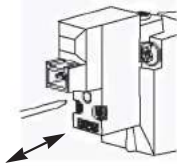

Pilot air exhaust port

1) Collection exhaustation

The DV series is a type that the pilot valve exhaustion is collected to the main valve. Be careful that the exhaustion port is clear of obstruction. The P, R port is on both sides of the manifold and you can select the exhaust direction according to the installation location. The P port exhaustion must have the appropriate size for the exhaust connection hole in order to prevent an output deficiency of the actuator and operational errors due to a shortage in pressure. Make sure to use plenty of exhaustion port on both sides to ensure no operational errors occur due to exhaustion resistance when you are installing the R port noise device.

2) Individual exhaust

- ① Since it is in to type of individual exhaustation that releases air in the pilot valve into atmosphere, it cannot be used in places requiring high purity.
- ② Use connector type(H or V) to exhaust(grouped exhaustation) pilot air in grouped state through main valve.

[Using the 3 port valve]

The DV series has a specification of a 5 port valve but if you are using a 3 port valve use one direction of a cylinder port (A,B) to stop up the plug and you will be able to use the Normal Close (N,C) or Normal Open (N,O) 3 port valve.

Except, use with the exhaust port(R1, R2) open.

Location of the plug		B port	A port
Conversion Method		N.C	N.O
Number of Solenoids	Single		
	Double		

Cautions for wiring and use

- 1) Be careful to prevent connector case of solenoid coil or lamp from being broken by shock.

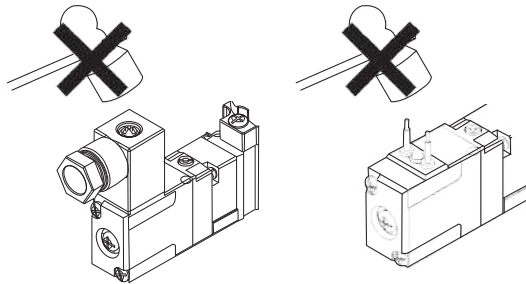

- 2) Do not assemble/disassemble screw at the center of solenoid coil, because it is used to fasten the core.

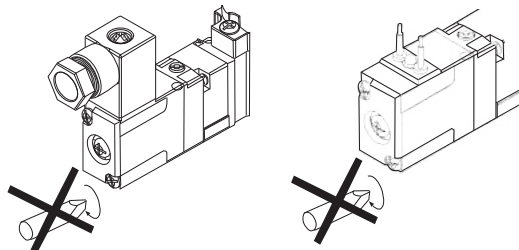

Series DV4000

! Precautions

- 3) Avoid the following places where the life of valve may be radically reduced.
 - a. Place with much dust, moisture, vibration or shock
 - b. Place subject to the influence of salt, corrosive gas and chemicals
 - c. Place where the neighboring temperature is not in the range of 0~60°C(32~140°F)
- 4) By operating solenoid valve, keep the fluctuation of rated voltage within + / -10% of rated voltage. Otherwise, malfunction may be caused or coil may be damaged.
- 5) Surge voltage that generated while supplying/blocking power to/at solenoid valve may affect magnetic circuit adversely. Thus, it is required to prepare measure for this problem in the case of PLC control.
- 6) Though power is blocked, operation may continue due to leakage current in the magnetic circuit. Thus, be sure to keep the residual leakage current at both ends under 20% of rated voltage for AC and under 3% of rated voltage for DC.
- 7) Valves of AC 110V, AC 220V Specification
Our valve is a non-standard option specification solenoid Coil which you may ask about when ordering.

<DC>

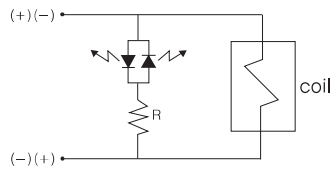

<AC>

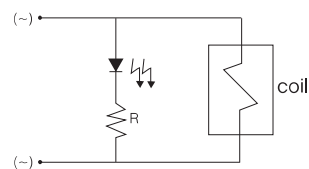

How to use the plug connector

When you are installing the connector hold the lever and connector body with your hands and insert the connector in the connector housing, then lock it by pressing in the connector lever hook. When you are separating the connector press the lever to disconnect the hook from the connector housing home. When you are pulling the lead line too lightly or put too much force it will result in poor connections or disconnections.

[How to use DIN Connector]

Wiring

- 1) Be sure to loosen set screw and pull out the connector from the terminal block of the solenoid.
- 2) To separate block and housing, be sure to pull out screw and insert a screwdriver to the slit area near the bottom of terminal block.
- 3) To separate block and housing, and affix it securely with the terminal screw, it is preferred to loose terminal screw of terminal block, it is preferred to place bare end of the bottom of terminal block.
- 4) Be sure to tighten ground nut to secure the wire.

! Caution

Use the cable (ø3.5 to ø7) for wiring to meet IP65 standard(enclosure). Tighten the ground nut and set screw with the specified range of torque.

Change of electrical entry(Orientation)

After separating terminal block and housing, mount housing at any position(total 4 directions, per 90 degrees), therefore, changing electrical entry.

* In the case of indicator light, avoid damaging the light with lead wire.

Precautions

Plug connector in vertically, never at an angle.

DW

DR100

DR200

RS1000,
2000

RS4000

SI UNIT

DV1000
DV3000
DV4000

DS300

DS3000

DS5000

DS2000

DS6000

DX1,DX2

DX1(2)R

DH

DP300
DP3000
DP5000

DM

DT220